



**Centre for Distance and Online Education  
Punjabi University, Patiala**

---

**Class : B.A. II (Math)  
Paper : III (Mechanics)  
Medium : English**

**Semester : III  
Unit-2**

---

***Lesson No.***

- 2.1 : DYNAMICS-I  
2.2 : DYNAMICS-II  
2.3 : DYNAMICS-III  
2.4 : DYNAMICS-IV

---

***Department website : [www.pbide.org](http://www.pbide.org)***

**B.A. / B.Sc. (MATHEMATICS) Semester - III**

**PAPER-III: MECHANICS**

**Maximum Marks: 50**  
**Maximum Time: 3 Hrs**

**Pass Percentage: 35%**

**INSTRUCTIONS FOR THE PAPER SETTER**

The question paper will consist of three sections A, B and C. Sections A and B will have four questions each from the respective sections of the syllabus and Section C will consist of one compulsory question having eight short answer type questions covering the entire syllabus uniformly. Each question in sections A and B will be of 7.5 marks and Section C will be of 20 marks.

**INSTRUCTIONS FOR THE CANDIDATES**

Candidates are required to attempt five questions in all selecting two questions from each of the Section A and B and compulsory question of Section C.

**Section-A**

Basic notation, Newton's laws of motion, System of two forces, Parallelogram law of forces, Resultant of two collinear forces, Resolution of forces, Moment of a force, Couple, Theorem on moments of a couple, Coplanar forces, Resultant of three coplanar concurrent forces, Theorem of resolved parts, Resultant of two forces acting on a rigid body, Varignon's theorem, Generalized theorem of moments. Equilibrium of two concurrent forces, Equilibrium condition for any number of coplanar concurrent forces, Lami's theorem,  $\Lambda$ -  $\mu$  theorem, Theorem of moments, Resultant of a force and a couple, Equilibrium conditions for coplanar non-concurrent forces.

**Section-B**

Motion of a particle with constant acceleration, Acceleration of falling bodies, Motion of a falling body, Motion of a body projected vertically upwards, Motion of two particles connected by a string, Motion along a smooth inclined plane, Variable acceleration, Simple harmonic motion, Projectile.

**RECOMMENDED BOOKS:**

1. S. L. Loney : The Elements of Statics and Dynamics, 5<sup>th</sup> Edition, Cambridge University Press, 1947
2. John L. Synge, Byron A. Griffith : Principles of Mechanics, 3<sup>rd</sup> Edition, McGraw Hill International Student Editions, 1959.

LAST UPDATED: MAY, 2023

**B.A. PART - II  
SEMESTER-III**

**PAPER-III  
MECHANICS**

---

**LESSON NO. 2.1**

**Author : Dr. Chanchal**

---

## **DYNAMICS-I**

- 2.1.1 Objectives**
- 2.1.2 Introduction**
- 2.1.3 Expression for Velocity and Acceleration at a Point**
- 2.1.4 System of Units**
- 2.1.5 Equations of Motion (With Constant Acceleration)**
- 2.1.6 Distance Travelled in nth Second**
- 2.1.7 Acceleration of Falling Bodies (Vertical Motion Under Gravity)**
  - 2.1.7.1 For a Body Projected Vertically Upwards**
- 2.1.8 Velocity-Time Graph**
- 2.1.9 Some Important Examples**
- 2.1.10 Summary**
- 2.1.11 Key Concepts**
- 2.1.12 Long Questions**
- 2.1.13 Short Questions**
- 2.1.14 Suggested Readings**

### **2.1.1 Objectives**

The main objectives of this lessons are :

- To discuss about the various terms involved with the motion of a particle.
- To study equations of motion with constant acceleration.
- To study the vertical motion under gravity including free fall and projection upwards with some initial velocity.

### **2.1.2 Introduction**

Dynamics may be defined as that branch of mechanics which deals with the motion of bodies under the action of given forces. It is further divided into two parts : one part is kinematics which deals with displacement, velocity, acceleration and time, and relations between these without taking reference to the forces which cause motion. The other part is called kinetics which deals with the study of forces acting on the

moving body.

Now use introduce some basic concepts of dynamics as follows :

- (i) **Rest (Position of Equilibrium) :** A body is said to be at rest if it does not change its position relative to its surroundings with time.
- (ii) **Motion :** A body is said to be in motion if it. Changes its position with time.
- (iii) **Path :** The straight line or the curve along which a moving particle travels is called its path.
- (iv) **Rectilinear & Curvilinear Motion :** If the path is a straight line, then the motion is called rectilinear and if the path is a curve, then the motion is said to be curvilinear.
- (v) **Displacement :** The displacement of a particle during an interval is the directed distance between its initial and final positions during the interval. Since the displacement has both the characteristic magnitude and direction, so it is a vector quantity, It is generally denoted by  $x$  or  $s$ .
- (vi) **Velocity & Speed :** The rate of change of displacement w.r.t. time is called velocity. It is generally denoted by  $v$ . It is a vector quantity as it has both magnitude and direction. Moreover, the magnitude of velocity is called speed.
- (vii) **Uniform Velocity :** If a particle describes equal distances in equal intervals of time, however small the interval, then it is said to be moving with uniform velocity. In other words if a particle is moving such that the magnitude of the velocity is constant and there is no change in its direction, then we say that particle is moving with uniform velocity. In this case particle is said to have a uniform motion.
- (viii) **Acceleration :** The rate of change of velocity w.r.t. time is called acceleration. It is a vector quantity. If a particle moves such that its velocity decreases, then the acceleration is negative and is called retardation. Moreover, if the particle is moving with uniform velocity then, its acceleration is zero.
- (ix) **Uniform Acceleration :** When velocity of a particle moving in a straight line changes by equal amounts in equal intervals of time, however small, the particle is said to move with uniform acceleration.

### 2.1.3 Expression for Velocity and Acceleration at a Point

Let a particle move along the line OX, where O is taken as origin.

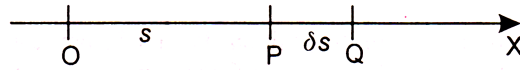

Let P and Q be the positions of the particle at time  $t$  and  $t + \delta t$  such that

$$OP = s, OQ = s + \delta s$$

$$\therefore \text{displacement of the particle in time } \delta t = (s + \delta s) - s = \delta s$$

$$\therefore \text{average velocity during time } \delta t = \frac{\delta s}{\delta t}$$

$$\therefore \text{velocity of the particle at time } t = \lim_{\delta t \rightarrow 0} \frac{\delta s}{\delta t} = \frac{ds}{dt}$$

$$\therefore v = \frac{ds}{dt} \text{ where } v \text{ is the velocity at any time } t.$$

In order to find the expression for acceleration at a point, Suppose that  $v$  and  $v + \delta v$  be the velocities of the particle at time  $t$  and  $t + \delta t$  respectively.

$$\therefore \text{change in velocity in time interval } \delta t = (v + \delta v) - v = \delta v$$

$$\therefore \text{average rate of change of velocity in time interval } \delta t = \frac{\delta v}{\delta t}$$

$$\therefore \text{acceleration of the particle at time } t = \lim_{\delta t \rightarrow 0} \frac{\delta v}{\delta t} = \frac{dv}{dt}$$

$$\therefore a = \frac{dv}{dt} \text{ where } a \text{ is the acceleration at time } t.$$

$$\text{Further, } a = \frac{dv}{dt} = \frac{d}{dt} \left( \frac{ds}{dt} \right) = \frac{d^2s}{dt^2}$$

$$\text{Also, } a = \frac{dv}{dt} = \frac{dv}{ds} \cdot \frac{ds}{dt} = \frac{dv}{ds} \cdot v = v \frac{dv}{ds}$$

$$\therefore a = \frac{dv}{dt} \text{ or } \frac{d^2s}{dt^2} \text{ or } v \frac{dv}{ds}$$

#### 2.1.4 System of Units

The important systems of units are

- (i) The Foot-Point-Second System (FPS-System)

In this system, the units for length, mass and time are foot, pound and second respectively.

(ii) The Centimetre-Gram-Second System (CGS-System)

In this system, the units for length, mass and time are centimetre, gram and second respectively.

(iii) The Metre-Kilogram-Second System (MKS-System)

In this system, the units for length, mass and time are metre, kilogram and second respectively.

### 2.1.5 Equations of Motion (With Constant Acceleration)

**Art 1 :** A particle moves along a straight line from a fixed point in it with initial velocity  $u$  and constant acceleration  $a$ , in its direction of motion. If  $s$  be the distance of the particle from the origin at time  $t$  and  $v$  be the velocity attained at that time, prove that

$$(i) \quad v = u + at \qquad (ii) \quad s = ut + \frac{1}{2}at^2$$

$$(iii) \quad v^2 = u^2 + 2as$$

**Proof :** The acceleration of the particle is given constant and equal to  $a$  and  $s$  is the distance at any time  $t$  from the point at which it starts, then its equation of motion is

$$\frac{d^2s}{dt^2} = a$$

Integrating w.r.t.,  $t$ , we get,

$$\frac{ds}{dt} = at + c, \text{ where } c \text{ is a constant}$$

Initially when  $t = 0$ ,  $\frac{ds}{dt} = u$

$$\therefore u = 0 + c, \text{ or } c = u$$

$$\therefore \frac{ds}{dt} = at + u \quad \text{or} \quad v = u + at \qquad \dots (1)$$

which give the velocity  $v$  at any time  $t$ .

from (1),  $\frac{ds}{dt} = u + at$

Integrating w.r.t.t, we get,

$$s = ut + \frac{1}{2}at^2 + k, \text{ where } k \text{ is a constant.}$$

Initially when  $t = 0$ ,  $s = 0$

$$\therefore 0 = 0 + 0 + k \text{ or } s = 0$$

$$\therefore s = ut + \frac{1}{2}at^2 \quad \dots (2)$$

which give the distance  $s$  at any time  $t$ .

(iii) The equation of motion is  $v = \frac{dv}{ds} = a$

Separating variables, we get,  $v \, dv = a \, ds$

Integrating,  $\frac{v^2}{2} = as + k'$ , where  $k'$  is a constant.

Initially when  $v = u$ ,  $s = 0$

$$\therefore \frac{u^2}{2} = 0 + k' \text{ or } k' = \frac{u^2}{2}$$

$$\therefore \frac{v^2}{2} = as + \frac{u^2}{2} \text{ or } v^2 = 2as + u^2$$

$$\text{or } v^2 = u^2 + 2as.$$

### 2.1.6 Distance Travelled in nth Second

In rectilinear motion with uniform acceleration, prove that distance travelled in thenth

$$\text{second} = u + \frac{1}{2}(2n-1)a$$

where  $u$  and  $a$  have their usual meaning.

**Proof :** Let  $u$  be the initial velocity and  $a$  be the constant acceleration of the particle.

$\therefore$  distance travelled in the  $n$ th second

$$= [\text{Distance travelled in } n \text{ seconds}] - [\text{Distance travelled in } (n-1) \text{ seconds}]$$

$$= \left[ un + \frac{1}{2}an^2 \right] - \left[ u(n-1) + \frac{1}{2}a(n-1)^2 \right]$$

$$= \left[ un + \frac{1}{2}an^2 \right] - \left[ un - u + \frac{1}{2}an^2 - an + \frac{1}{2}a \right]$$

$$= un + \frac{1}{2}an^2 - un + u - \frac{1}{2}an^2 + an - \frac{1}{2}a = u + an - \frac{1}{2}a = u + a\left(n - \frac{1}{2}\right)$$

$$\therefore s_n = u + \frac{1}{2}(2n - 1)a$$

where  $s_n$  denotes the distance travelled in the  $n$ th second.

### Some Important Results :

- (1) In rectilinear motion with constant acceleration, the distances described in successive seconds form an A.P.
- (2) In rectilinear motion with constant acceleration, the average velocity during an interval of time is the mean of the initial and final velocities and is equal to the velocity at the middle of the interval.
- (3) In rectilinear motion with constant acceleration, the distance travelled in time  $t$  is equal to the product of time  $t$  and the mean of the initial and final velocities.

The above results are left as an exercise for the reader to prove.

### 2.1.7 Acceleration of Falling Bodies (Vertical Motion Under Gravity)

When any body is allowed to fall from some height, at a particular place on the earth, then the body moves vertically downwards with constant acceleration. This constant acceleration is known as acceleration due to gravity, denoted by the letter  $a$  and  $g = 9.8 \text{ m/sec}^2$ . If the body is coming downwards, then  $g$  is positive and we replace ' $a$ ' by ' $g$ ' in the equations of motion. But, if the body is moving upwards, then  $g$  is negative and we replace ' $a$ ' by ' $-g$ ' in the equations of motion.

#### 2.1.7.1 For a Body Projected Vertically Upwards

**Art 2 :** A particle is projected vertically upwards with velocity  $u$ . Find

- (i) its velocity after time  $t$ ;
- (ii) the height ascended by it in time  $t$ ;
- (iii) its velocity at a height  $h <$  (the greatest height attainable);
- (iv) the maximum height attained;
- (v) the time to reach a given height  $h$  (less than the maximum). Explaining the double answer;
- (vi) the time to reach the highest point;
- (vii) the total time of flight;
- (viii) its velocity on return to the point of projection.

**Proof :** During the upwards motion, the acceleration is  $-g$ . Here  $u$  is the initial velocity of projection.



$$(i) \quad \therefore v = u - gt \quad [\because v = u + at]$$

(ii) Let  $h$  be the height attained in time  $t$ .

$$\therefore h = ut - \frac{1}{2}gt^2 \quad \left[ \because s = ut + \frac{1}{2}at^2 \right]$$

$$(iii) \quad \text{Now } v^2 = u^2 - 2gh \quad [\because v^2 = u^2 + 2as]$$

$$\therefore v = \pm \sqrt{u^2 - 2gh}$$

### Explanation of the double answer

As the particle is moving upward under retardation, so it will come to rest at some height and then move downwards with acceleration  $g$  and once again attains height  $h$ . The positive velocity is at the height  $h$  while ascending and the negative velocity is at the same height  $h$  while descending. The two velocities are equal in magnitude.

(iv) Let  $H$  be the maximum height reached. Now at the maximum height  $H$ , we have  $v = 0$

$$\therefore (0)^2 = u^2 - 2gH \text{ or } u^2 = 2gH \quad [\because v^2 = u^2 + 2as]$$

$$\therefore \text{maximum height reached, } H = \frac{u^2}{2g}$$

$$(v) \quad \text{Here } h = ut - \frac{1}{2}gt^2 \quad \left[ \because s = ut + \frac{1}{2}at^2 \right]$$

$$\Rightarrow 2h = 2ut - gt^2 \quad \Rightarrow \quad gt^2 - 2ut + 2h = 0$$

$$\Rightarrow t = \frac{2u \pm \sqrt{4u^2 - 8gh}}{2g} = \frac{u \pm \sqrt{u^2 - 2gh}}{g}$$

### Explanation for double answer

From above, we get two values of  $t$ . One value of  $t$  given us the time to reach a point in the upward motion and the other is the time to reach the same point in the descent after the particle has reached the highest point.

(vi) Let  $T$  be the time to reach the greatest height. At the greatest height, we have  $v = 0$

$$\therefore 0 = u - gT \quad [\because v = u + at]$$

$$\Rightarrow u = gT \Rightarrow \text{time to reach the greatest height, } T = \frac{u}{g}$$

(vii) When the particle comes back to the point of projection, then  $h = 0$

$$\therefore 0 = ut + \frac{1}{2}gt^2 \Rightarrow t \left( u - \frac{1}{2}gt \right) = v \quad \left[ \because s = ut + \frac{1}{2}at^2 \right]$$

$$\Rightarrow t = 0, \frac{2u}{g}$$

where  $t = 0$  gives us the time at the time of projection

$\therefore$  we have  $t = \frac{2u}{g}$ , which is the time of flight i.e., time to reach maximum height and then to its original position.

**Note :** Time of flighty i.e., of going and coming back =  $\frac{2u}{g}$

Also the time to reach max. height =  $\frac{u}{g}$

$$\therefore \text{time of descent} = \frac{2u}{g} - \frac{u}{g} = \frac{u}{g}.$$

$$\therefore \text{time of ascent} = \text{time of descent} = \frac{u}{g}.$$

(viii) At the point of projection,  $h = 0$

$$\therefore v^2 = u^2 - 2g \cdot 0 \quad \left[ \because u^2 + 2as \right]$$

$$\Rightarrow v^2 = u^2 \quad \Rightarrow v = \pm u$$

Rejecting the positive sign which corresponds to the initial velocity, we have

$$v = -u.$$

$$\therefore \text{required velocity} = -u.$$

### 2.1.8 Velocity–Time Graph

Let OT and OV be two straight lines at right angles to each other. Take these two lines as the axes of reference. Let  $t$ , the time taken by a particle, be represented by distance along OT, and  $v$ , the corresponding velocity of the particle, be represented by distance along OV, Then the curve traced by the point P ( $t, v$ ) is called the velocity-time graph.

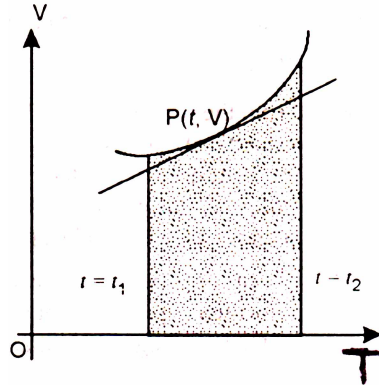

The slope of the tangent at P (t, v) =  $\frac{dv}{dt}$

$\therefore$  slope represent the acceleration of the particle at time t.

Again the area under the graph, shown shaded in the figure, between two ordinates t

$$= t_1 \text{ and } t = t_2 = \int_{t_1}^{t_2} v \, dt = \int_{t_1}^{t_2} \frac{ds}{dt} \, dt = [s]_{s_1}^{s_2}$$

where  $s_1$  = distance moved in time  $t_1$

and  $s_2$  = distance moved in time  $t_2$

=  $s_2 - s_1$  = distance moved from  $t_1$  to  $t_2$ .

**Note :** The equations of motion (given in Art 1.1) can also be proved with the help of velocity time graph (Do Yourself).

### 2.1.9 Some Important Examples

**Example 1 :** The position of a particle moving along the x-axis is given by the relation :

$$x = t^3 - 9t^2 + 24t$$

where x is the distance in metres from the origin and t is the time in seconds. The particle is 16m. to the right of the origin when  $t = 1$  sec. Determine

- (i) the position of the particle when the velocity is zero.
- (ii) the acceleration when  $t = 2$  secs.
- (iii) the distance travelled during the interval  $t = 0$  to  $t = 2$  secs.
- (iv) the displacement from  $t = 0$  to  $t = 2$  secs.

**Sol.** Here  $x = t^3 - 9t^2 + 24t$

... (1)

$$\therefore v = \frac{dx}{dt} = 3t^2 - 18t + 24 \quad \dots (2)$$

$$\text{and } f = \frac{dv}{dt} = 6t - 18 \quad \dots (3)$$

(i) When  $v = 0$ , from (2),  $3t^2 - 18t + 24 = 0$

or  $t^2 - 6t + 8 = 0$  or  $(t-2)(t-4) = 0$

$\therefore t = 2$  or  $4$  secs.

Thus the velocity is zero when  $t = 2$  secs. or  $t = 4$  secs.,

Putting  $t = 2$  in (1),  $x = 8 - 36 + 48 = 20\text{m}$

Putting  $t = 4$  in (1),  $x = 64 - 144 + 96 = 16\text{m}$

Hence, the position of the particle when its velocity is zero is at 20m or 16m to the right of the origin.

(ii) Putting  $t = 2$  in (3), we have,

$$a = 12 - 18 = -6 \text{ m/sec}^2$$

Hence acceleration =  $-6\text{m/sec}^2$  when  $t = 2$  sec.

(iii) Putting  $t = 0$  in (1),  $x = 0$

Putting  $t = 2$  in (1),  $x = 8 - 36 + 48 = 20\text{m}$

The velocity becomes zero for the first time when  $t = 2$  sec.

$\therefore$  from  $t = 0$  to  $t = 2$  sec, the motion is in the same direction



Distance travelled during the interval  $t = 0$  to  $t = 2$  sec =  $|OQ| = 20$  m

(iv) Displacement from  $t = 0$  to  $t = 2$  sec is given by

$$\begin{aligned} & (\text{Co-ordinate of Q}) - (\text{Co-ordinate of O}) \\ & = 20 - 0 = 20 \text{ m.} \end{aligned}$$

**Example 2 :** A particle moves to the right from rest with an acceleration of  $5 \text{ m/sec}^2$  until its velocity is  $19 \text{ m/sec}$ . to the right. It is then subjected to an acceleration of  $10 \text{ m/sec}^2$  to the left until its total distance travelled is  $40 \text{ m}$ . Determine the total elapsed time.

**Sol.** Let O be the starting point and A be the position of the particle when its velocity is  $10 \text{ m/sec}$ . Let  $OA = s$  and  $t$  be the time from O to A.

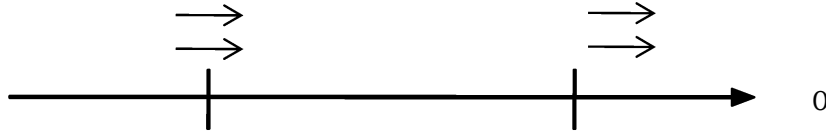

$$\therefore u = 0, a = 5 \text{ m/sec}^2, v = 10 \text{ m/sec}$$

$$\text{Now } v = u + at \Rightarrow 10 = 0 + 5t \Rightarrow t = 2 \text{ seconds.}$$

$$\text{Also } s = ut + \frac{1}{2}at^2 \Rightarrow s = (0)(2) + \frac{1}{2}(5)(2)^2 = 10 \text{ m}$$

$$\therefore OA = 10 \text{ m and time } t \text{ from } O \text{ to } A = 2 \text{ seconds.}$$

Now when the particle reaches A, it is subjected to an acceleration  $10 \text{ m/sec}^2$  to the left. so its velocity will decrease after A. Let the particle come to rest at B such that  $AB = s_1$  and  $t_1$  is the time from A to B.

For motion from A to B

$$u = 10 \text{ m/sec}, v = 0 \text{ m/sec}, a = -10 \text{ m/sec}^2, t = t_1, s = s_1$$

$$\text{Now } v = u + at \Rightarrow 0 = 10 - 10t_1 \Rightarrow t_1 = 1 \text{ second.}$$

$$s = ut + \frac{1}{2}at^2 \Rightarrow s_1 = (10)(1) + \frac{1}{2}(-10)(1)^2 = s_1 = 5 \text{ m}$$

Now velocity at B is zero and AC is towards left. So the particle starts moving towards O. Let the particle be at C when it has covered a total distance of 40m.

$$\therefore BC = 40 - [OA + AB] = 40 - [10 + 5] = 25 \text{ m}$$

For motion from B to C

$$u = 0, a = 10 \text{ m/sec}^2, s_2 = BC = 25 \text{ m.}$$

Let  $t_2$  be the time from B to C.

$$\therefore s_2 = ut_2 + \frac{1}{2}at_2^2 \Rightarrow 25 = 0(t_2) + \frac{1}{2}(10)t_2^2$$

$$\Rightarrow 25 = 5t_2^2 \Rightarrow t_2^2 = 5 \Rightarrow t_2 = \sqrt{5} \text{ seconds.}$$

$$\therefore \text{total time taken} = t + t_1 + t_2 = 2 + 1 + \sqrt{5} = (3 + \sqrt{5}) \text{ seconds.}$$

**Example 3 :** A particle moving with uniform acceleration in a straight line passes point P, Q, R. If  $PQ = QR = b$  and if the time from P to Q is  $t_1$ , Q to R is  $t_2$ , prove that the

acceleration is  $\frac{2b(t_1 - t_2)}{t_1 t_2 (t_1 + t_2)}$ .

**Sol.** Let  $u$  be the velocity of the particle at P and  $f$  be the constant acceleration.

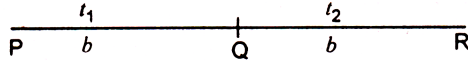

For motion from P to Q,

$$s = b, t = t_1$$

$$\therefore s = ut + \frac{1}{2}at^2 \Rightarrow b = ut_1 + \frac{1}{2}at_1^2 \quad \dots (1)$$

For motion from P to R,

$$s = 2b, t = t_1 + t_2$$

$$\therefore s = ut + \frac{1}{2}at^2 \Rightarrow 2b = u(t_1 + t_2) + \frac{1}{2}(t_1 + t_2)^2 \quad \dots (2)$$

We want to eliminate  $u$  from (1) and (2).

Multiplying (1) by  $t_1 + t_2$  and (2) by  $t_1$ , we get,

$$b(t_1 + t_2) = ut_1(t_1 + t_2) + \frac{1}{2}(t_1 + t_2)t_1^2 \quad \dots (3)$$

$$\text{and } 2bt_1 = ut_1(t_1 + t_2) + \frac{1}{2}at_1(t_1 + t_2)^2 \quad \dots (4)$$

Subtracting (4) from (3), we get,

$$b[(t_1 + t_2) - 2t_1] = \frac{1}{2}at_1(t_1 + t_2)[t_1 - (t_1 + t_2)]$$

$$\text{or } b(t_2 - t_1) = \frac{1}{2}at_1(t_1 + t_2)[-t_2]$$

$$\text{or } 2b(t_2 - t_1) = -at_1 t_2 (t_1 + t_2) \Rightarrow a = \frac{2b(t_1 - t_2)}{t_1 t_2 (t_1 + t_2)}$$

**Example 4 :** A, B, C are three points vertically below the point O such that  $OA = AB = BC$ . If the particle falls from rest at O, then prove that times of describing OA, AB and BC are as  $1 : (\sqrt{2} - 1) : (\sqrt{3} - \sqrt{2})$ .

**Sol.** Since the particle falls from rest at O,  $\therefore u = 0$

Let OA = AB = BC = h metres and  $t_1, t_2, t_3$  seconds be the time taken by the particle to describe OA, AB, BC respectively.

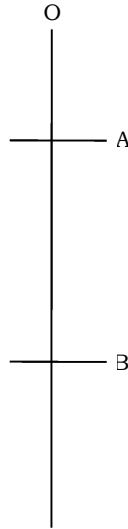

For motion from O to A

$$u = 0, s = h, t = t_1$$

$$\therefore h = \frac{1}{2}gt_1^2 \Rightarrow t_1 = \sqrt{\frac{2h}{g}}$$

For motion from O to B

$$u = 0, s = 2h, t = t_1 + t_2$$

$$\therefore 2h = \frac{1}{2}g(t_1 + t_2)^2 \Rightarrow t_1 + t_2 = \sqrt{\frac{4h}{g}}$$

$$\therefore t_2 = \sqrt{\frac{4h}{g}} - t_1 = \sqrt{\frac{4h}{g}} - \sqrt{\frac{2h}{g}} \quad [ \because \text{of (1)} ]$$

$$\therefore t_2 = (\sqrt{2} - 1) \sqrt{\frac{2h}{g}} \quad \dots (2)$$

For motion from O to C

$$u = 0, s = 3h, t = t_1 + t_2 + t_3$$

$$\begin{aligned} \therefore 3h &= g(t_1 + t_2 + t_3)^2 \Rightarrow t_1 + t_2 + t_3 = \sqrt{\frac{6h}{g}} \\ \Rightarrow t_3 &= \sqrt{\frac{6h}{g}} - \sqrt{\frac{4h}{g}} && \left[ \because t_1 + t_2 = \sqrt{\frac{4h}{g}} \right] \\ \Rightarrow t_3 &= (\sqrt{3} - \sqrt{2}) \sqrt{\frac{2h}{g}} && \dots (3) \end{aligned}$$

From (1), (2) and (3), we get,

$$t_1 : t_2 : t_3 = 1 : (\sqrt{2} - 1) : (\sqrt{3} - \sqrt{2}).$$

**Example 5 :** A particle projected vertically upwards takes time  $t_1$  to reach a height

$h$ . If  $t_2$  is the time to reach the ground again, prove that  $h = \frac{1}{2}gt_1t_2$  and the maximum

height attained is  $\frac{1}{8}g(t_1 + t_2)^2$ . Show also that the velocity of particle at a height

$$\frac{h}{2} \text{ is } \frac{1}{2}g\sqrt{t_1^2 + t_2^2}.$$

**Sol.** Let  $u$  be the velocity of projection.

Now time taken to reach height  $h$  is  $t_1$  and the time taken after this to reach the ground =  $t_2$

$$\therefore \text{time of flight} = t_1 + t_2$$

$$\Rightarrow \frac{2u}{g} = t_1 + t_2 \Rightarrow u = \frac{1}{2}g(t_1 + t_2) \quad \dots (1)$$

$$\text{Now } h = ut_1 - \frac{1}{2}gt_1^2$$

$$\therefore h = \frac{1}{2}g(t_1 + t_2)t_1 - \frac{1}{2}gt_1^2 \quad [\because \text{of (1)}]$$

$$= \frac{1}{2}gt_1[t_1 + t_2 - t_1] = \frac{1}{2}gt_1t_2$$



$$\therefore h = \frac{1}{2}gt_1t_2 \quad \dots (2)$$

$$\text{Maximum height attained} = \frac{u^2}{2g} = \frac{\frac{1}{4}g^2(t_1+t_2)^2}{2g} = \frac{1}{8}g(t_1+t_2)^2 \quad [\because \text{of (1)}]$$

Let  $v$  be the velocity at height  $\frac{h}{2}$ .

$$\begin{aligned} \therefore v^2 &= u^2 - 2g\left(\frac{h}{2}\right) \\ &= \frac{1}{4}g^2(t_1+t_2)^2 - 2g\left(\frac{1}{2} \cdot \frac{1}{2}gt_1t_2\right) \end{aligned} \quad [\because \text{of (1), (2)}]$$

$$= \frac{1}{4}g^2(t_1+t_2)^2 - \frac{1}{2}g^2t_1t_2 = \frac{1}{4}g^2[(t_1+t_2)^2 - 2t_1t_2] = \frac{1}{4}g^2(t_1^2 + t_2^2)$$

$$\therefore v = \frac{1}{2}g\sqrt{t_1^2 + t_2^2}.$$

### 2.1.10 Summary

In this lesson, we dealt with the motion of a particle with constant acceleration/ uniform acceleration. Moreover, we have also studied the motion of particles vertically experiencing the acceleration due to gravity. The velocity-time graph is also explained. The evaluation of terms related to the motion of a particle are made more elaborative using suitable examples.

#### 2.1.11 Key Concepts

Rest, Motion, Velocity, Acceleration, Uniform Velocity, Uniform Acceleration, Curvilinear motion, Rectilinear motion, System of units, Equations of motion, Vertical motion, Acceleration due to gravity, Velocity-time graph.

#### 2.1.12 Long Questions

1. A particle moves in a straight line with constant acceleration. During the first second of observation it moves 17m and during the next two seconds it moves 52m. What is its acceleration ?
2. Two particles P and Q start from a point A in a straight line AB with velocities  $u$  and  $u'$  and move with accelerations  $a$  and  $a'$ . If both have

the same velocity at the mid-point of AB, prove that  $AB = \frac{u'^2 - u^2}{a - a'}$ .

3. A particle starts with velocity  $u$  and moves in a straight line with constant acceleration. When the velocity of the particle has increased to  $4u$ , the acceleration is reversed in direction. Find the velocity of the particle when it reaches the starting point.
4. Show that the times after which a particle, projected vertically upwards, is half of its greatest height bear to one another the ratio  $(\sqrt{2} + 1) : (\sqrt{2} - 1)$ .
5. A stone falling under gravity travels 34.3 metres in the last second of its flight. Find the height through which it fell and the time of its falling.

### 2.1.13 Short Questions

1. Prove that distance travelled in time  $t$  is equal to product of  $t$  and the mean of initial and final velocities.
2. A particle starting from rest with uniform acceleration describes 9.8m in the tenth second of its motion. Find the acceleration.
3. A particle falls from the top of a roof. Determine the distance travelled by it in the 4<sup>th</sup> second of its fall.

### 2.1.14 Suggested Readings

1. S.L. Loney : The Elements of Statics and Dynamics, 5th Edition, Cambridge University Press, 1947.

## **DYNAMICS-II**

- 2.2.1 Objectives**
- 2.2.2 Introduction**
- 2.2.3 Motion of Two Particles Connected by a String**
- 2.2.4 Motion Along a Smooth Inclined Plane**
- 2.2.5 Constrained Motion Along a Smooth Inclined Plane**
- 2.2.6 Newton's Law of Gravitational Attraction**
- 2.2.7 Some Important Examples**
- 2.2.8 Summary**
- 2.2.9 Key Concepts**
- 2.2.10 Long Questions**
- 2.2.11 Short Questions**
- 2.2.12 Suggested Readings**

### **2.2.1 Objectives**

In the previous lesson, we have dealt with kinematics in which we have discussed the quantities, time, displacement, velocity, acceleration and relations between these, without considering the forces that cause motion.

### **2.2.2 Introduction**

In this lesson, use focus on the motion of the body by taking into account the mass of the body and the forces that cause motion. For studying kinetics further, firstly we introduce Newton's laws of motion as follows :-

- (1) Newton's First Law of Motion :** A body continues in its state of rest or of uniform in a straight line, unless an external force (or impressed force) is applied on it to change its state of rest or of uniform motion. This first law of motion also implies the following Principle :-  
**Principle of Intertia :** It states that a body has no tendency of itself to change its state of rest or motion and if it is kept free from the action of external forces, it will remain in its state of rest or of uniform motion

in a straight line.

- (2) Newton's Second Law of Motion :** The rate of change of momentum of a body is proportional to the impressed force and it takes place in the direction of the force. Let a body of mass 'm' be moving in a straight line with velocity 'v' at any time 't'. So, momentum,  $p = mv$  - (1)  
Let F is the force acting on the body of mass m. By Newton's

2<sup>nd</sup> Law  $\rightarrow \frac{dp}{dt} \propto F \Rightarrow \frac{d}{dt}(mv) = KF$ , -(2) where K is the constant of proportionality whose value depends upon the units chosen.

$$\text{Now, (2) gives : } m \frac{dv}{dt} = KF \Rightarrow F = \frac{1}{K} ma$$

Let the unit of force be so chosen that unit for acting on unit mass (m=1) produces unit acceleration (a = 1)

i.e. F = 1 when m = 1, a = 1, then, k = 1

$\therefore F = ma$  which is called fundamental equation of dynamics.

### Units of Force :

#### I. Absolute (or Fundamental) Units of Force :

In C.G.S. system unit of force is dyne. One dyne is that force which produces in a mass of one gram an acceleration of 1 cm/sec<sup>2</sup> in its own direction.

In M.K.S. system, unit of force is newton. One newton is that force which produces in a mass of one kilogram an acceleration of 1 m/sec<sup>2</sup> in its own direction.

#### II. Gravitational (or Practical) Units of Force :

In C.G.S. system, gravitational unit of force is called "gram-weight" (gm-wt). It is that much force which produces an acceleration of  $g = 981 \text{ cm/sec}^2$  in a mass of 1 gram.

In M.K.S. system, gravitational unit of force is called "kilogram-weight" (kg-wt). It is that much force which produced an acceleration of  $g = 9.8 \text{ m/sec}^2$  in a mass of 1 kilogram.

**Note :** One kilogram weight = 9.8 newtons and one gram weight = 981 (or 980) dynes.

- (3) Newton's Third Law of Motion :** To every action there corresponds an equal and opposite reaction.

#### 2.2.3 Motion of Two Particles Connected by a String

Suppose a piece of string AB is acted on by forces F and F' at its ends A and B. Consider the string as a body of mass m. Its equation of motion is

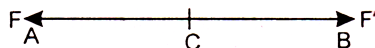

$$ma = F' - F$$

When  $a$  is finite and the weight of the string or its mass is negligible i.e.,  $m = 0$ , then

$$F' - F = 0 \Rightarrow F = F'$$

$\therefore$  the forces at the two ends of the string are equal.

Again by considering the portions AC and CB of the string, it can be shown that the pull at C on the portion AC along CB is equal to the pull on the portion BC at C along CA. Thus at any point of a string, the two portions of the string on the two sides may be regarded as pulling each other with a force which is the same throughout the string. This force is called the tension of the string.

*Therefore when the weight of a string is neglected the tension in the string is same throughout its length.*

**Art 1 :** Two masses,  $m_1$  and  $m_2$  ( $m_1 > m_2$ ) are suspended by a light inextensible and flexible string over a smooth, fixed, small, light pulley (or a peg). Find

(i) the acceleration of the masses, (ii) the tension in the string, (iii) the pressure on the pulley.

**Proof :** Let  $l$  be the length of the whole string and  $x, y$  be the depths of the masses  $m_1, m_2$  respectively below the top of the pulley at any time  $t$ .

Since the string is inextensible,  $\therefore x + y = l$

Differentiating both sides w.r.t.  $t$ , we get,

$$\frac{dx}{dt} + \frac{dy}{dt} = 0 \Rightarrow \frac{dx}{dt} = -\frac{dy}{dt}$$

$$\text{and } \frac{d^2x}{dt^2} = -\frac{d^2y}{dt^2}$$

Thus the velocity  $v$  and the acceleration  $f$  of the mass  $m_2$  upwards must same as those of mass  $m_1$  downwards, throughout the motion.

Also as the pulley is smooth,  $T$ . the tension of the string, is same throughout the string.

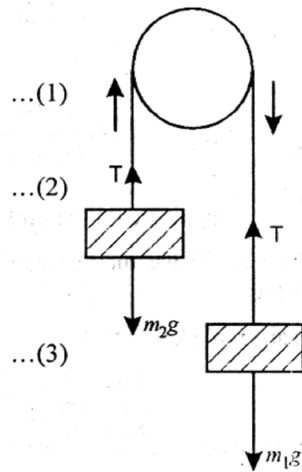

The equation of motion for mass  $m_1$  is

$$m_1 a = m_1 g - T$$

and the equation of motion for mass  $m_2$  is

$$m_2 a = T - m_2 g$$

(i) Adding (1) and (2), we get,

$$(m_1 + m_2) a = (m_1 - m_2) g$$

$$\therefore a = \frac{m_1 - m_2}{m_1 + m_2} g$$

which gives the acceleration of the system.

**Note :** When  $m_2 > m_1$ , then  $a$  is negative, Therefore  $m_1$  has an upward acceleration and  $m_2$  has downward acceleration. Hence, it is the heavier body which descends.

$$\text{Again } a = \frac{m_1 - m_2}{m_1 + m_2} g = \frac{\frac{m_1}{m_2} - 1}{\frac{m_1}{m_2} + 1} \cdot g$$

$\therefore$   $a$  depends upon the ratio masses of the two bodies and not upon their actual masses.

(ii) Putting  $a = \frac{m_1 - m_2}{m_1 + m_2} g$  (1), we get,

$$m_1 \left( \frac{m_1 - m_2}{m_1 + m_2} \right) g = m_1 g - T$$

$$\therefore T = m_1 g - m_1 \left( \frac{m_1 - m_2}{m_1 + m_2} \right) g$$

$$= m_1 g \left[ 1 - \frac{m_1 - m_2}{m_1 + m_2} \right] = m_1 g \left[ \frac{m_1 + m_2 - m_1 + m_2}{m_1 + m_2} \right] = m_1 g \left[ \frac{2m_2}{m_1 + m_2} \right]$$

$$\therefore T = \frac{2m_1 m_2}{m_1 + m_2} g$$

which gives the tension in the string.

(iii) Pressure on the pulley = Resultant of two forces of tension, each equal to T, acting downward

$$= 2T = \frac{4m_1 m_2}{m_1 + m_2} g$$

**Cor. 1 :** Prove that the pressure on the pulley is always less than the sum of the weights of the masses.

**Proof :** Sum of weights – pressure on the pulley

$$= m_1 g + m_2 g - \frac{4m_1 m_2}{m_1 + m_2} g$$

$$= g \left[ (m_1 + m_2) - \frac{4m_1 m_2}{m_1 + m_2} \right] = g \left[ \frac{(m_1 + m_2)^2 - 4m_1 m_2}{m_1 + m_2} \right]$$

$$= g \left[ \frac{(m_1 - m_2)^2}{m_1 + m_2} \right] > 0$$

$\therefore$  pressure on the pulley is always less than the sum of the weights of the masses.

**Cor. 2 :** Prove that tension in the string is the H.M. between the weights of the two bodies.

**Proof :** We know that

$$T = \frac{2m_1m_2}{m_1 + m_2}g$$

$$\therefore \frac{2}{T} = \left( \frac{m_1 + m_2}{m_1 + m_2} \right) g \Rightarrow \frac{2}{T} = \frac{1}{m_1g} + \frac{1}{m_2g}$$

$\therefore$  tension in the string is the H.M. between the weights of two bodies.

**Cor. 3 :** Prove that tension in the string is maximum when two bodies on each side

of pulley have equal masses and maximum tension =  $\frac{1}{2}$  sum of (weights). Also show

that in this case the system is either at rest or will be moving with uniform velocity.

**Proof :** Do Yourself.

### Atwood's Machine :

In Atwood's machine two equal weights are attached to the ends of a string and suspended over a light pulley running with as little friction as possible. Over one of the weights resting on the platform, an addition weight, called the rider, is put. The platform is dropped instantaneously and the system begins to move.

**Art 2 :** Two masses  $m_1, m_2$  are connected by an inelastic string ;  $m_2$  is placed on a smooth horizontal table and the string passes over a light smooth pulley at the edge of the table and  $m_1$  is hanging freely. Determine the motion and the tension in the string. Find also the pressure on the pulley.

**Proof :** Let  $l$  be the length of the string and at any instant, let  $x$  and  $y$  be the distances of masses  $m_2$  and  $m_1$  respectively from the edge of the table, then

$$x + y = l$$

$$\therefore \frac{dx}{dt} + \frac{dy}{dt} = 0 \Rightarrow \frac{dx}{dt} = -\frac{dy}{dt} \text{ and } \frac{d^2x}{dt^2} = -\frac{d^2y}{dt^2}$$

Thus the velocity and acceleration of  $m_1$ , vertically downwards are at all time equal to those of  $m_2$  along the table towards the edge. Let  $a$  be the common acceleration and  $T$  be the tension of the string.



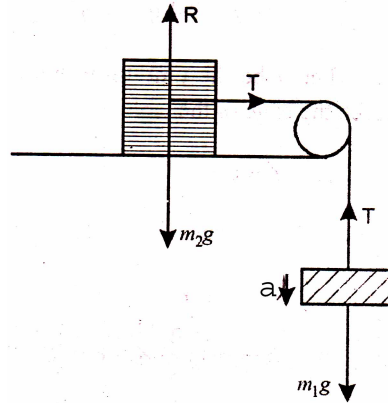

The equation of motion for mass  $m_1$  is

$$m_1 a = m_1 g - T \quad \dots (1)$$

The equation of motion for mass  $m_2$  in a horizontal direction is

$$m_2 a = T \quad \dots (2)$$

Adding (1) and (2), we get,

$$(m_1 + m_2) a = m_1 g$$

$$\therefore a = \frac{m_1}{m_1 + m_2} g$$

Putting this value of  $a$  in (2), we get,

$$T = \frac{m_1 m_2}{m_1 + m_2} g$$

Let  $R$  be the reaction of the table on the mass  $m_2$ . Since  $m_2$  does not move in a vertical direction.

$$\therefore m_2 \cdot 0 = R - m_2 g \Rightarrow R = m_2 g$$

The pulley is being pressed by the two equal forces  $T$  at right angles

$$\therefore \text{pressure on the pulley} = \sqrt{T^2 + T^2} = \sqrt{2T^2} = \sqrt{2} T = \sqrt{2} \frac{m_1 m_2}{m_1 + m_2} g$$

### 2.2.4 Motion Along a Smooth Inclined Plane

**Art 3 :** A body moves down a smooth inclined plane under the action of gravity alone, discuss its motion. Also, find (i) Time to reach the highest point, (ii) Distance of the highest point from the point of projection, (iii) Time of flight

**Proof :** Let  $m$  be the mass of the body and  $\alpha$  the inclination of the plane.

Since the plane is smooth, therefore there is no force of friction parallel to the plane opposing the motion of the mass.

The only forces acting on the body are :

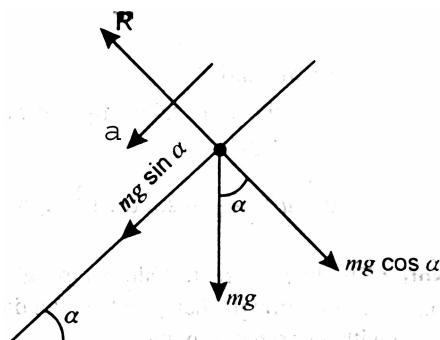

- (i) its weight  $mg$  acting vertically downwards
- (ii) the reaction  $R$  acting perpendicular to the plane.

The vertical force  $mg$  is equivalent to :

- (i) a force  $mg \cos \alpha$  perpendicular to the plane and
- (ii) a force  $mg \sin \alpha$  down the plane.

Since the mass  $m$  moves down the plane, its acceleration  $a$  acts down the plane.

Since there is no motion and, therefore, no acceleration perpendicular to the plane.

$$\therefore R - mg \cos \alpha = m \times 0$$

$$\Rightarrow R = mg \cos \alpha \quad \dots (1)$$

The motion of the body along the plane is given by

$$ma = mg \sin \alpha \Rightarrow a = g \sin \alpha \quad \dots (2)$$

Hence the body moves down the plane with a constant acceleration  $g \sin \alpha$  and it is, therefore, evident that the motion of a body, on a smooth inclined plane is similar to that of a body moving vertically under gravity, except that instead of  $g$  we have to take  $g \sin \alpha$  for acceleration.

Thus, if a body is projected up a smooth inclined plane along a line of greatest slope with an initial velocity  $u$ , then  $v$ , the velocity, and  $s$ , the distance described in time  $t$  are given by the equations.

$$v = u - g \sin \alpha \cdot T,$$

$$s = ut - \frac{1}{2}g \sin \alpha \cdot t^2$$

$$\text{and } v^2 = u^2 - 2g \sin \alpha \cdot s$$

- (i) Time to reach the highest point

At the highest point,  $v = 0$

$$\therefore 0 = u - g \sin \alpha \cdot t \Rightarrow t = \frac{u}{g \sin \alpha}$$

(ii) Distance of the highest point from the point of projection  
At the highest point  $v = 0$

$$\therefore 0 = u^2 - 2g \sin \alpha \cdot s \Rightarrow s = \frac{u^2}{2g \sin \alpha}$$

(iii) Time of Flight

Let  $T$  be the time taken by the body to return to the point of projection, so its displacement is zero.

$$\therefore 0 = uT - \frac{1}{2}g \sin \alpha \cdot T^2, T \neq 0 \Rightarrow T = \frac{2u}{g \sin \alpha}$$

### 2.2.5 Constrained Motion Along a Smooth Inclined Plane

**Art 4 :** A mass  $m_1$  hanging vertically is connected to another mass  $m_2$  placed on a smooth inclined plane of inclination  $\alpha$  by means of a light inelastic string passing over a smooth pulley fixed at the top of the plane. The system is released from rest, discuss the motion.

**Proof :** Let mass  $m_1$  move downwards with acceleration  $a$ .

Since  $m_2$  is connected by in-extensible string passing over a smooth pulley, so mass  $m_2$  will move up the plane with the same acceleration  $a$  and tension  $T$ , say, will be same throughout the string. Forces acting on mass  $m_2$  are

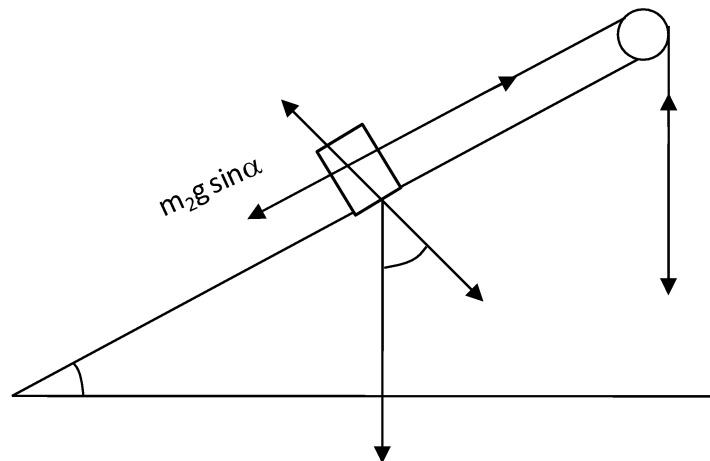

(i) its weight  $m_2 g$  acting vertically downwards which has got components  $m_2 g \sin \alpha$  down the plane and  $m_2 g \cos \alpha$  perpendicular to the plane.

(ii) normal reaction  $R$  and

(iii) tension  $T$  up the plane

Since  $m_2$  has no motion at right angles to the plane

$$\therefore m_2 \times 0 = R - m_2 g \cos \alpha \Rightarrow R = m_2 g \cos \alpha \quad \dots (1)$$

Forces acting on mass  $m_1$  are

(i) its weight  $m_1 g$  acting vertically downwards

(ii) tension  $T$  acting vertically upwards.

$$\text{The equation of motion of } m_1 \text{ is } m_1 a = m_1 g - T \quad \dots (2)$$

$$\text{The equation of motion of } m_2 \text{ is } m_2 a = T - m_2 g \sin \alpha \quad \dots (3)$$

Adding (2) and (3), we get,

$$(m_1 + m_2) a = (m_1 - m_2 \sin \alpha) g$$

$$\therefore a = \frac{m_1 - m_2 \sin \alpha}{m_1 + m_2} g \quad \dots (4)$$

From (2),

$$T = m_1 (g - a) = m_1 \left[ g - \frac{m_1 - m_2 \sin \alpha}{m_1 + m_2} g \right] \quad [\because \text{of (4)}]$$

$$= m_1 g \left[ \frac{m_1 + m_2 - m_1 + m_2 \sin \alpha}{m_1 + m_2} \right] = \frac{m_1 m_2 (1 + \sin \alpha)}{m_1 + m_2} g$$

Pressure on the pulley = resultant of two  $T$ ,  $T$  at an angle  $\left(\frac{\pi}{2} - \alpha\right)$ .

$$= \sqrt{T^2 + T^2 + 2T \cdot T \cos \left(\frac{\pi}{2} - \alpha\right)} = \sqrt{2T^2 + 2T^2 \sin \alpha} = \sqrt{2} T \sqrt{1 + \sin \alpha}$$

$$= \sqrt{2} \frac{m_1 m_2 (1 + \sin \alpha)^{\frac{3}{2}}}{m_1 + m_2} \cdot g.$$

Further, the system will not move, mass  $m_1$  will move down and mass  $m_2$  will move up

if  $a = 0$ ,  $a > 0$  and  $a < 0$  respectively i.e.,  $\frac{m_1 - m_2 \sin \alpha}{m_1 + m_2} g = 0$ ,  $\frac{m_1 - m_2 \sin \alpha}{m_1 + m_2} g > 0$  and

$$\frac{m_1 - m_2 \sin \alpha}{m_1 + m_2} g < 0 \text{ respectively,}$$

i.e.  $m_1 - m_2 \sin \alpha = 0$ ,  $m_1 - m_2 \sin \alpha > 0$  and  $m_1 - m_2 \sin \alpha < 0$  respectively

or  $\frac{m_1}{m_2} = \sin \alpha$ ,  $\frac{m_1}{m_2} > \sin \alpha$  and  $\frac{m_1}{m_2} < \sin \alpha$  respectively.

The system will have no motion if  $\frac{m_1}{m_2} = \sin \alpha$ , mass  $m_1$  will move down if  $\frac{m_1}{m_2} > \sin \alpha$

and mass  $m_1$  will move up if  $\frac{m_1}{m_2} < \sin \alpha$ .

**Art 5 :** Two smooth inclined planes of equal heights and inclinations  $\alpha$  and  $\beta$  are placed back to back. Masses  $m_1$ ,  $m_2$  resting on them are connected by a light inextensible string passing over a smooth pulley fixed at the common vertex of the two planes. If the system is free to move, discuss the motion.

**Proof :** Discuss Yourself

### 2.2.6 Newton's Law of Gravitational Attraction

**Statement.** Newton's law gravitational attraction states that the force of the attraction between two bodies varies directly to the product of their masses and inversely as the square of the distance between them.

The law is expressed by the equation

$$F = G \frac{M_1 M_2}{r^2}$$

where  $F$  = the magnitude of the force of mutual attraction between the two bodies,  $M_1$ ,  $M_2$  = the masses of the two bodies

$r$  = the distance between the bodies

$G$  = a universal constant known as the constant of gravitation which does not depend upon the nature of bodies involved.

### 2.2.7 Some Important Examples

**Example 1 :** An engine of mass 30 metric tons pulls a train of 130 metric tons.

Supporting the friction to be  $\frac{1}{40}$ th of the weight of the whole train, calculate the

force exerted by the engine, if at the end of the first kilometre from rest, the speed be raised to 18 km. p.h.

**Sol.** Mass of engine = 30 metric tons

Mass of train = 130 metric tons

∴ mass of whole train = 30 + 130 = 160 metric tons

Resistance =  $\frac{1}{40} \times 160 = 4$  metric tons wt. = 4000 kg. wt.

Now  $u = 0, s = 1 \text{ km} = 1000\text{m}, v = 18\text{km./hr.} = \frac{18 \times 1000}{60 \times 60} = 5\text{m/sec}$

Now  $v^2 = u^2 + 2as \Rightarrow (5)^2 = (0)^2 + 2a \times 1000$   $a = \frac{1}{80} \text{m/sec}^2$

Let P newtons be the pull of engine.

F, Effective force = Pull of engine - resistance =  $(P - 4000 \text{ g})$  newtons

Now  $F = ma \Rightarrow P - 4000 \text{ g} = 160000 \times \frac{1}{80}$

$\Rightarrow P = 4000\text{g} + 2000 = 1000(4\text{g} + 2)$  newtons

$= \frac{1000}{\text{g}}(4\text{g} + 2) \text{kg. wt.} = \left(4 + \frac{2}{\text{g}}\right)$  metric tons wt.

$= \left(4 + \frac{2}{9.8}\right)$  metric tons wt. = 4.2 metric tons wt.

**Example 2 :** Two masses are connected by a string passing over a small pulley. Show that if the sum of the masses be constant, the greater the acceleration, the less is the tension in the string.

**Sol.** Let  $m_1$  and  $m_2$  be the two masses so that  $m_1 + m_2 = m$ , a constant quantity

Now  $a = \frac{m_1 - m_2}{m_1 + m_2} g = \frac{m_1 - m_2}{m} g$

and  $T = \frac{2m_1 m_2}{m_1 + m_2} g = \frac{2m_1 m_2}{m} g$

From (1), we get,

$$a^2 = \frac{(m_1 - m_2)^2}{m^2} g^2 = \left[ (m_1 + m_2)^2 - 4m_1 m_2 \right] \frac{g^2}{m^2}$$

$$= (m^2 - 4m_1 m_2) \frac{g^2}{m^2} = g^2 - \frac{4m_1 m_2}{m^2} g^2 = g^2 - \frac{2g}{m} \cdot \frac{2m_1 m_2}{m}$$

$$\therefore a^2 = g^2 - \frac{2g}{m} T$$

$\therefore$  the lesser the value of  $T$ , the greater is the value of  $a$  i.e., the greater the acceleration, the less is the tension in the string.

**Example 3 :** A string passes over a smooth fixed pulley and to one end the is attached a mass  $m_1$  and to the other smooth light pulley over which passes another string with masses  $m_2$  and  $m_3$  at the ends. If the system is released for rest, show that  $m_1$  will not

move if  $\frac{4}{m_1} = \frac{1}{m_2} + \frac{1}{m_3}$ .

**Sol.** Let  $T$  be the tension in the string passing over the smooth fixed pulley A and  $T'$  be the tension in the string passing over the smooth fixed pulley B.

$\therefore$  pressure on pulley B =  $2T'$

$$= 2 \cdot \frac{2m_2m_3g}{m_2 + m_3} = \frac{4m_2m_3}{m_2 + m_3}$$

Now mass  $m_1$  will not move if  $T = m_1g$  and pulley B will not move if  $T = 2T'$

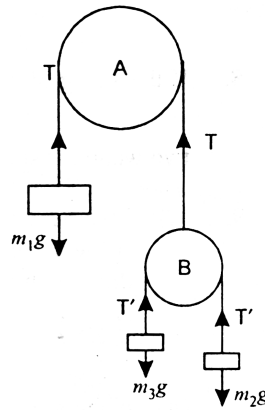

i.e., if  $m_1g = \frac{4m_2m_3}{m_2 + m_3} g$

i.e., if  $m_1 = \frac{4m_2m_3}{m_2 + m_3}$

i.e., if  $\frac{4}{m_1} = \frac{m_2m_3}{m_2 + m_3}$

i.e., if 
$$\frac{4}{m_1} = \frac{1}{m_2} + \frac{1}{m_3} .$$

**Example 4 :** A particle of mass 0.2 kg. lies on a smooth table at a distance of 6 metres from the edge of the table. It is connected to a mass 0.4 kg. by a light string which passes over a pulley fixed at the edge of the table. The mass of 0.4 kg. is hanging vertically. If the system starts from rest, how long will it take the 0.2 kg. mass to reach the edge of the table.

**Sol.** Let a  $m/sec^2$  be the acceleration of the system and T newtons be the tension in the string.

The equation of motions of masses are

$$0.4 a = 0.4 g - T$$

and  $0.2 a = T$

Adding (1) and (2), we get

$$0.6a = 0.4g \Rightarrow a = \frac{2}{3}g \text{ m/sec}^2$$

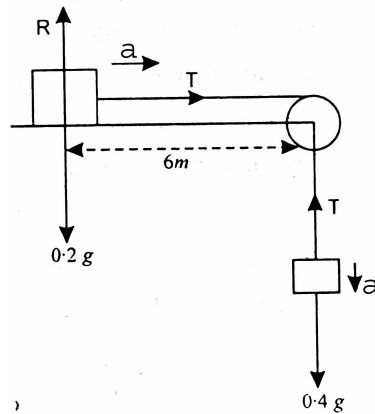

Let  $t$  be the time taken by the 0.2 kg. mass to reach the edge of the table

$$\therefore 6 = 0.t + \frac{1}{2} \times \frac{2}{3}g \times t^2$$

$$\left[ \because s = ut + \frac{1}{2}at^2 \right]$$

$$\Rightarrow 6 = \frac{1}{2} \times \frac{2}{3} \times 9.8 \times t^2 \quad \Rightarrow t^2 = \frac{18}{9.8} = \frac{90}{49}$$



$$\Rightarrow t = \frac{3}{7} \sqrt{10} \text{ seconds} = 1.355 \text{ seconds.}$$

**Example 5 :** A block of 80 kg is placed on an inclined of 3 in 5. Find the horizontal force required to produce in the block an acceleration of  $4\text{m/sec}^2$  up the inclined plane. Find also the pressure on the inclined plane.

**Sol.** The forces acting on the block are :

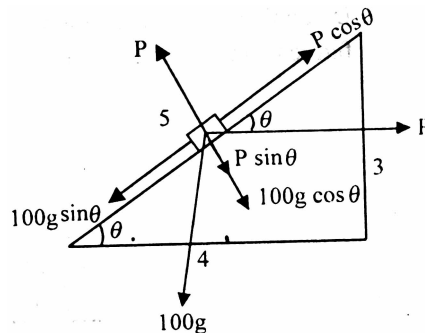

(i) Its weight  $100g$  N acting vertically downwards. It can be resolved into two components  $100g \sin \theta$  down the plane and  $100g \cos \theta$  perpendicular to the plane.

(ii) The force  $P$  acting horizontally. It can be resolved into components  $P \cos \theta$  up the plane and  $P \sin \theta$  perpendicular to the plane.

(iii) Relation  $R$  of the plane perpendicular to the plane. The effective force up the plane is  $= P \cos \theta - 100g \sin \theta$

$\therefore$  The equation of motion of the block up the plane is

$$P \cos \theta - 100g \sin \theta = 100 \times 4$$

$$\frac{4P}{5} - 100(9.8) \frac{3}{5} = 400$$

$$\frac{4P}{5} = 400 + 2 \times 98 \times 3 = 400 + 588 = 988 \text{ N}$$

$$P = \frac{988 \times 5}{4} = 1235 \text{ N}$$

As there is no motion  $\perp$  to the plane

$$R = P \sin \theta + 100g \cos \theta = 1235 \times \frac{3}{5} + 100 \times 9.8 \times \frac{4}{5}$$

$$= 741 + 784 = 1525 \text{ N.}$$

**Example 6 :** A body of mass 1.2kg. is placed on an inclined plane whose height is half its length. It is connected by a light string passing over a pulley at the top of the plane with a mass of 0.8 kg. which hangs vertically. Find the distance described by each of the masses in 5 seconds they start from rest.

**Sol.** Let height AC = h, then length AB = 2h. If  $\theta$  is the inclination of the plane, then

$$\sin \theta = \frac{AC}{AB} = \frac{1}{2}$$

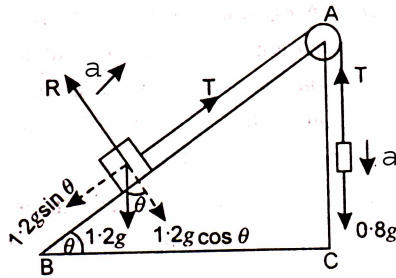

$$\Rightarrow \theta = 30^\circ$$

Let T newtons be the tension in the string and  $a \text{ m/sec}^2$ , the acceleration of the system.

Equation of motion of the mass on the plane is

$$T - 1.2 g \sin \theta = 1.2 a \quad \dots (1)$$

Equation of motion of the hanging mass is

$$0.8 g - T = 0.8 a$$

Adding (1) and (2), we get, ... (2)

$$0.8 g - 1.2 g \sin \theta = 2 a$$

$$\Rightarrow 0.8g - 1.2g \times \frac{1}{2} = 2a \quad \left[ \because \sin \theta = \sin 30^\circ = \frac{1}{2} \right]$$

$$\Rightarrow 0.2 g = 2a$$

$$\therefore a = 0.1 \times 9.8 = .98 \text{ m/sec}^2.$$

Now each mass describes the same distance = s (say), one up the plane and the other vertically downwards.

Using  $s = ut + \frac{1}{2}at^2$ , we have

$$s = 0 + \frac{1}{2}(.98)(5)^2 = 12.25 \text{ m.}$$

### 2.2.8 Summary

In this lesson, we have reviewed Newton's laws of motions. We have focused on various physical terms involved during motion of two particles connected by a string, motion along a smooth inclined plane under the action of gravity and constrained motion along a smooth inclined plane. Moreover, we have also stated Newton's law of gravitational attraction and solved various examples based upon it.

### 2.2.9 Key Concepts

Newton's laws of motion, Gravitational units, Absolute units, Motion, String, Atwood's machine, Inclined plane, Gravity, Inelastic string, Newton's law of gravitational attraction.

### 2.2.10 Long Questions

1. If the string of an Atwood's machine can bear a strain of only  $\frac{1}{8}$  of the sum of two weights ; show that the least possible acceleration is  $\frac{\sqrt{3}}{2}g$ .
2. A weight of 10 kg. is attached to one end of a string. Find the weight which must be attached to the other end in order that when the system is suspended from a fixed pulley, the acceleration may be  $\frac{g}{3}$ .
3. Two particles P and Q are attached to the ends of a light string the particle P is placed on a smooth horizontal table while Q hangs over the edge and the system moves freely under gravity. The mass Q is 1kg. If P starts from rest and moves 2.45 m in the first second, determine the mass of P.

### 2.2.11 Short Questions

1. A particle moves in a straight line according to the law  $x = t^3 - 75t$ , where  $x$  denotes the distances in metres and  $t$ , the time in seconds. If the particle weighs 6kg., what is the resultant force on it at 3 seconds.
2. An astronaut has a mass of 70 kg. How much will he weigh on the surface of the moon ?
3. State Newton's law of gravitational attraction.

### 2.2.12 Suggested Readings

1. S.L. Loney : The Elements of Statics and Dynamics, 5th Edition, Cambridge University Press, 1947.

LAST UPDATED: MAY, 2023

**B.A. PART - II  
(SEMESTER-III)**

**PAPER-III  
MECHANICS**

**LESSON NO. 2.3**

**Author : Dr. Chanchal**

---

### **DYNAMICS-III**

---

- 2.3.1 Objectives**
- 2.3.2 Introduction**
- 2.3.3 Motion Under Gravity Outside the Surface of Earth**
- 2.3.4 Simple Harmonic Motion (S.H.M)**
  - 2.3.4.1 Nature of S.H.M.**
  - 2.3.4.2 Periodic Motion**
- 2.3.5 Elastic String**
  - 2.3.5.1 Horizontal Elastic String**
- 2.3.6 Simple Pendulum**
  - 2.3.6.1 Second Pendulum**
  - 2.3.6.2 Pendulum at a height 'h'**
  - 2.3.6.3 Pendulum at a depth 'h'**
- 2.3.7 Some Important Examples**
- 2.3.8 Summary**
- 2.3.9 Key Concepts**
- 2.3.10 Long Questions**
- 2.3.11 Short Questions**
- 2.3.12 Suggested Readings**

#### **2.3.1 Objectives**

In this lesson, our prime objective is to study the motion of a particle with variable acceleration. During the study, our main points of interest are:

- To study motion under gravity outside the surface of earth using Newton's law of gravitational attraction
- To study simple harmonic motion (SHM) and periodic motion
- To study horizontal elastic string (a special case of SHM)
- To discuss simple pendulum (a special case of SHM) and associated physical terms with it

- To get the knowledge of second pendulum (a special case of simple pendulum)

### 2.3.2 Introduction

In the previous lessons, we have discussed motion of particle with and without taking reference to the forces acting on it. In both the cases, the motion is with constant acceleration. Now, in this lesson, we consider the motion with variable acceleration. Moreover, the acceleration can vary w.r.t. time, velocity and displacement. Also, we have obtained three different expressions for acceleration

'a' :  $\frac{d^2s}{dt^2}$ ,  $\frac{dv}{dt}$ ,  $v \frac{dv}{ds}$ . Therefore, the equation  $F = ma$  can be written in three different

ways :

$$m \frac{d^2s}{dt^2} = F \quad \dots (1)$$

$$\text{or} \quad m \frac{dv}{dt} = F \quad \dots (2)$$

$$\text{or} \quad mv \frac{dv}{ds} = F \quad \dots (3)$$

If acceleration 'a' is a function of time 't', then (1) or (2) can be used. If 'a' is a function of velocity 'v', then (2) or (3) can be used and if 'a' is a function of distance 's', then (1) only (3) can be used.

### 2.3.3 Motion Under Gravity Outside the Surface of Earth

In the previous lesson, we have stated Newton's law of gravitational attraction. It is this law which governs the motion of a body outside the surface of earth.

If M be the mass of the earth and m, that of the particle situated at a distance x from the centre of earth, then F the force of attraction between them is given by

$$F = G \frac{Mm}{x^2} \quad \dots (1)$$

where G is the universal constant of gravitation. Due to this attraction, if a is the acceleration generated in the particle, then

$$F = ma \quad \dots (2)$$

From (1) and (2), we get,

$$G \frac{Mm}{x^2} = ma$$

$$\Rightarrow a = \frac{Gm}{x^2} = \frac{k}{x^2}, \text{ where } k = GM \text{ is constant} \quad \dots (3)$$

$$\Rightarrow a \propto \frac{1}{x^2}$$

Hence the acceleration produced in bodies outside the surface of earth is inversely proportional to the square of the distance of the body from the centre of the earth.

### 2.3.4 Simple Harmonic Motion (S.H.M)

A particle is said to execute Simple Harmonic Motion if it moves in a straight line such that its acceleration is always directed towards a fixed point in the line and is proportional to the distance of the particle from the fixed point.

**Art 1 :** A particle moves in a straight line such that its acceleration is always directed towards a fixed point in the line and is proportional to the displacement of the particle from the fixed point. Find the expressions for the velocity and position of the particle at any time.

**Proof :** Let O be the fixed point in the line  $A_1OA$  and let P denote the particle after time t from O moving with a velocity v in the positive direction from O to A. Let  $OP = x$ , then the acceleration is  $\mu x$ , where  $\mu$  is constant.

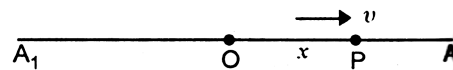

Since the acceleration is in the direction opposite to that in which x increases, the equation of motion of the particle is

$$v \frac{dv}{dx} = -\mu x \quad \dots (1)$$

Separating the variables,  $v dv = -\mu x dx$

$$\text{Integrating, } \frac{v^2}{2} = -\frac{\mu x^2}{2} + c_1 \quad \dots (2)$$

where  $c_1$  is constant of integration.

As P is supposed to be moving in the direction OA and as the acceleration is given to be taking place in the opposite direction, the particle P must come to rest at some point in OA, say at A such that  $OA = a$ .

$$\therefore v = 0 \text{ when } x = a$$

$$\therefore \text{ from (2), } 0 = -\frac{1}{2}\mu a^2 + c_1 \Rightarrow c_1 = \frac{1}{2}\mu a^2$$

Putting  $c_1 = \frac{1}{2}\mu a^2$  in (2), we get,

$$\frac{v^2}{2} = -\mu \frac{x^2}{2} + \frac{1}{2}\mu a^2 \Rightarrow v^2 = \mu(a^2 - x^2)$$

$$\Rightarrow v = \pm \sqrt{\mu} \sqrt{a^2 - x^2} \quad \dots (3)$$

This equation gives the value of the velocity  $v$  for any displacement  $x$ . Since  $P$  is moving in the positive direction

$$\therefore v = \sqrt{\mu} \sqrt{a^2 - x^2} \Rightarrow \frac{dx}{dt} = \sqrt{\mu} \sqrt{a^2 - x^2}$$

Separating the variables, we get,

$$\frac{1}{\sqrt{a^2 - x^2}} dx = \sqrt{\mu} dt$$

$$\text{Integrating, } \sin^{-1} \frac{x}{a} = \sqrt{\mu} t + c_2 \quad \dots (4)$$

where  $c_2$  is constant of integration.

(i) If the time  $t$  is measured from the instant when  $P$  is at  $O$  i.e. if  $x = 0$  when  $t = 0$ , then from (4),

$$\sin^{-1} 0 = 0 + c_2 \Rightarrow c_2 = 0 \text{ as } \sin^{-1} 0 = 0$$

Putting  $c_2 = 0$  in (4), we get,

$$\sin^{-1} \frac{x}{a} = \sqrt{\mu} t \Rightarrow \frac{x}{a} = \sin \sqrt{\mu} t$$

$$\Rightarrow x = a \sin \sqrt{\mu} t \quad \dots (5)$$

(ii) If the time  $t$  is measured from the instant when the particle is at  $A$  i.e. if  $x = a$  when  $t = 0$ , then  $\sin^{-1} 1 = 0 + c_2$

$$\Rightarrow \frac{\pi}{2} = c_2 \text{ as } \sin^{-1} 1 = \frac{\pi}{2}$$

Putting  $c_2 = \frac{\pi}{2}$  in (4), we get,

$$\sin^{-1} \frac{x}{a} = \sqrt{\mu} t + \frac{\pi}{2} \text{ or } \frac{x}{a} = \sin \left( \frac{\pi}{2} + \sqrt{\mu} t \right)$$

$$\Rightarrow \frac{x}{a} = \cos \sqrt{\mu} t \Rightarrow x = a \cos \sqrt{\mu} t$$

Equation (5) or (6) gives the position of the particle at any time  $t$ .

**Remarks :** The fixed point  $O$  is called the centre of attraction or oscillation or the mean position or the position of equilibrium. In this position, the acceleration is zero and so the force acting on the particle is zero.

We have  $a = -\mu x$ . So it is clear that  $a$  is negative when  $x$  is positive and  $a$  is positive when  $x$  is negative. Thus, in both the cases, the acceleration and hence the force tries to bring the body back to the equilibrium position. Such a force is called restoring force.

When the particle is on the left hand side of  $O$ , the equation of motion is  $v \frac{dv}{dx} =$

acceleration in the direction of  $A_1P = \mu OP$   
 $= \mu (-x) = -\mu x$ .

Hence the same equation that holds on the right a hand side of  $O$ , holds also on the left hand side.

The points  $A$  and  $A_1$ , where the velocity is zero, are called the extreme positions or positions of rest. For these positions,  $x = a, -a$ .

**Amplitude** The distance  $OA = OA_1 = a$  is called the amplitude of S.H.M.

$v = \pm \sqrt{\mu} \sqrt{a^2 - x^2}$  shows that the particle has equal and opposite velocities at a point according as it is moving in the direction  $O$  to  $A$  or in the direction  $A$  to  $O$ .

### Cor 1. Maximum and Minimum Velocities

We have  $v^2 = \mu (a^2 - x^2)$

$\therefore v$  is maximum when  $x$  is least i.e.  $x = 0$ .

$\therefore$  max. velocity  $= \sqrt{\mu} \sqrt{a^2 - 0} = \sqrt{\mu} a$ , which occurs at the mean position

Again  $v$  is minimum when  $x$  is greatest in magnitude i.e.  $x = a, -a$

$\therefore$  particle has maximum velocity  $\sqrt{\mu} a$  at  $O$  and minimum velocity zero at

$A$  or  $A_1$ .

### Cor 2. Maximum and Minimum Accelerations

We have  $a = -\mu x$

$\therefore$  acceleration (in magnitude) is maximum when  $x = a$  or  $-a$  and max.



acceleration =  $\mu a$  and acceleration is minimum when  $x$  is minimum i.e.  $x = 0$  and min. acceleration = 0.

$\therefore$  particle has max. acceleration  $\mu a$  at the extreme position A or  $A_1$  and has minimum acceleration zero at the mean position O.

### 2.3.4.1 Nature of S.H.M.

Let O be the fixed point in the line  $A_1OA$  and let P denote the particle after  $t$  from O moving with a velocity  $v$  in the position direction from O to A. Let  $OP = x$ ,  $OA = a$

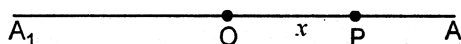

$$\therefore v = \pm \sqrt{\mu} \sqrt{a^2 - x^2}$$

gives the velocity of P in terms of its distance from O. Initially when  $x = 0$  at the point O, the velocity is maximum and equal to  $\sqrt{\mu} a$ . As the particle proceeds towards A, then acceleration being towards O, the velocity goes on decreasing as  $x$  increases. At A where  $x = a$ , it vanishes and the particle is, for an instant, at rest. Then owing to the acceleration towards O, the particle moves in the negative direction with a velocity which increases numerically as  $x$  decreases and is the greatest at O where it is  $-\sqrt{\mu} a$ . Due to this velocity, the particle proceeds further to the negative side of O, the velocity remaining negative and decreases gradually in magnitude till the particle comes to rest at  $A_1$ , where  $x = -a$ . The acceleration being towards O, the particle starts and moves towards O with a positive velocity which increases gradually till it is again maximum at O. The same motion is repeated again and again and the particle goes on oscillating indefinitely between A and  $A_1$ , the two positions of momentary rest.

### 2.3.4.2 Periodic Motion

A particle is said to have a periodic motion when it moves in a such a manner that after a certain fixed interval of time, it occupies the same position and moves, in the same direction with the same velocity.

The fixed minimal interval of time for such a motion is called the period of the motion.

**Art 2 :** Prove that Simple Harmonic Motion is periodic with period  $\frac{2\pi}{\sqrt{\mu}}$ .

**Proof :** Let  $x$  be the displacement of the particle and  $v$  its velocity at any time  $t$ , measured from the centre of oscillation.

$\therefore$  we have

$$x = a \sin \sqrt{\mu} t \quad \dots (1)$$

$$\text{and } v = a\sqrt{\mu} \cos \sqrt{\mu} t \quad \dots (2)$$

$$\left[ \because v = \frac{dx}{dt} \right]$$

We know that  $\sin \theta$  and  $\cos \theta$  are periodic functions of  $\theta$ , the period in each case being  $2\pi$ . That is to say, the value of  $\sin \theta$  and  $\cos \theta$  is repeated when  $\theta$  is increased by  $2\pi$ .

Therefore the values of  $x$  and  $v$  are repeated when  $\sqrt{\mu} t$  is increased by  $2\pi$  or when  $t$  is

increased by  $\frac{2\pi}{\sqrt{\mu}}$ .

Thus, after every interval of  $\frac{2\pi}{\sqrt{\mu}}$ , we have the same position and same velocity in the same direction.

Therefore the motion is periodic, the period being  $\frac{2\pi}{\sqrt{\mu}}$  (which is independent of amplitude)

**Remark :** Frequency is the number of complete oscillations in one second, so that if  $n$  denotes the frequency and  $T$  the periodic time.

$$nT = 1 \text{ or } n = \frac{1}{T} = \frac{\sqrt{\mu}}{2\pi}$$

It should be noted that frequency is reciprocal of the periodic time.

### 2.3.5 Elastic String

A string which stretches under the influence of a force is called an elastic string. If an elastic string is fixed at one point and pulled within limits at the other, it is found to increase in length. This extension in the string is proportional directly to the product of the tension and the natural length of the string and inversely to the area of the cross-section of the string. If  $x$ ,  $l$ ,  $T$ ,  $A$  denote extension, natural length, tension and area of cross-section, then

$$x = \frac{T l}{\lambda A} \quad \text{or} \quad T = \lambda \frac{A x}{l}$$

where  $\lambda$  (called the modulus of elasticity) is a constant depending on the material of the string.

If the unit of area of cross-section is so chosen that  $A = 1$  unit area, then  $T = \lambda \frac{x}{l}$ .

This is Hooke's Law. It states that tension of an elastic string is proportional to the extension of the string beyond its natural length.

**Note.** If  $l$  is the natural length and  $l'$  the extended length of the string, then  $x = l' - l$

$$\therefore T = \lambda \cdot \frac{l' - l}{l}$$

### 2.3.5.1 Horizontal Elastic String

Let one end of an elastic string be fixed to a point O on a smooth horizontal table and let  $OA = l$  be its natural length.

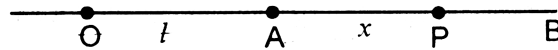

If a particle of mass  $m$  is attached to the other end and if the particle is displaced along the line OA, a distance  $AB = b$  and P be the position of the particle at, any subsequent

time so that  $AP = x$ , then, by Hooke's law, the tension in the string is  $\lambda \frac{x}{l}$  which acts in the direction PA and is directed towards A.

The tension of the string being the only force which tends to move the particle, its equation of motion is

$$m \frac{d^2x}{dt^2} = -T \quad \text{or} \quad m \frac{d^2x}{dt^2} = -\frac{\lambda}{l} x \quad \text{or} \quad \frac{d^2x}{dt^2} = -\frac{\lambda}{l m} x$$

which shows that the motion about A is simple harmonic.

Comparing  $\frac{d^2x}{dt^2} = -\frac{\lambda}{l m} x$  with  $\frac{d^2x}{dt^2} = -\mu x$ , we get,

$$\mu = \frac{\lambda}{l m}. \text{ Therefore time period} = 2\pi \sqrt{\frac{m l}{\lambda}} \quad \dots\dots (1)$$

The equation of motion can also be written as

$$v \frac{dv}{dx} = -\frac{\lambda}{l m} x \text{ or } v dv = -\frac{\lambda}{l m} x dx$$

$$\text{Integrating, } \frac{v^2}{2} = -\frac{\lambda}{l m} \frac{x^2}{2} + c$$

$$\text{At B, } x = b \text{ and } v = 0, \therefore 0 = -\frac{\lambda}{l m} \frac{b^2}{2} + c \Rightarrow c = \frac{\lambda b^2}{2lm}$$

$$\therefore \frac{v^2}{2} = -\frac{\lambda}{2lm} x^2 + \frac{\lambda b^2}{2lm} \Rightarrow v^2 = \frac{\lambda}{lm} (b^2 - x^2)$$

$$\Rightarrow v = -\sqrt{\frac{\lambda}{lm}} \sqrt{b^2 - x^2}$$

the sign is taken negative as the particle is moving towards O.

**Note :** In the similar manner, reader may discuss the motion in vertical elastic string.

### 2.3.6 Simple Pendulum

If a heavy particle, tied to one end of a light inextensible string, the other end of which is fixed, oscillates in a vertical circle, the system is called a simple pendulum. Let O be the fixed point,  $l$  the length of the string, A the lowest position of the particle of mass  $m$ . Let P be the position of the particle at any time  $t$  such that  $\angle AOP = \theta$  (radians). Here  $\theta$  is the small angular displacement in a vertical plane.

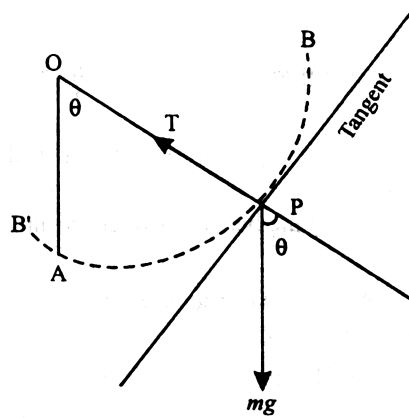

The forces acting on the particle are

- (i) its weight  $mg$  acting vertically downwards.
- (ii) the tension  $T$  in the string along PO.

The equation of motion of the particle along the tangent to the circle at P is

$$m.l \frac{d^2\theta}{dt^2} = -mg \sin \theta$$

$$\left[ \because \text{acceleration along the tangent to a circle of radius } l \text{ is } l \frac{d^2\theta}{dt^2} \right]$$

$$\text{or } l \frac{d^2\theta}{dt^2} = -g \sin \theta \quad \text{or } l \frac{d^2\theta}{dt^2} = -g\theta \quad [\because \sin \theta = \theta \text{ as } \theta \text{ is small}]$$

$$\text{or } \frac{d^2\theta}{dt^2} = -\frac{g}{l}\theta$$

The equation shows that the motion is simple harmonic and the time period.

$$T = \frac{2\pi}{\sqrt{\frac{g}{l}}} = 2\pi \sqrt{\frac{l}{g}}$$

**Remarks :** The length  $l$  of the string is called the length of the simple pendulum. The time period depends upon  $l$  and the value of  $g$  at a place but is independent of  $\theta$ , provided it is small.

If the equation of motion is of the form  $\frac{d^2x}{dt^2} = -\frac{g}{\lambda}x$ , then the motion is oscillatory and the period of oscillation is the same as that of simple pendulum of length  $\lambda$ . Then  $\lambda$  is called the length of equivalent simple pendulum.

### 2.3.6.1 Second Pendulum

Let B', B be the extremities of the path of the simple pendulum.

$$\therefore \text{time from B to B' and back of B} = 2\pi \sqrt{\frac{l}{g}}$$

$$\therefore \text{time from B to B'} = \frac{1}{2} \cdot 2\pi \sqrt{\frac{l}{g}} = \pi \sqrt{\frac{l}{g}}$$

We know that pendulum of a clock beats at each extremity.

$$\therefore \text{time between two consecutive beats} = \pi \sqrt{\frac{l}{g}}$$

A simple pendulum is called a second pendulum if the time interval between two consecutive beats is one second.

Let  $n$  be the number of beats in a given time interval  $T$

$$\therefore T = n \times \text{time of one beat} \Rightarrow T = n \times \pi \sqrt{\frac{l}{g}} \therefore n = \frac{T}{\pi} \sqrt{\frac{g}{l}} \quad \dots (1)$$

Taking log on both sides of (1)

$$\log n = \log \left( \frac{T}{\pi} \sqrt{\frac{g}{l}} \right)$$

$$\therefore \log n = \log \left( \frac{T}{\pi} \right) + \frac{1}{2} (\log g - \log l)$$

Taking differentials of both sides, we get,

$$\frac{1}{n} dn = \frac{1}{2} \left( \frac{1}{g} dg - \frac{1}{l} dl \right) \quad \left( \because \frac{T}{\pi} \text{ is constant} \right)$$

$$\therefore dn = \frac{n}{2} \left( \frac{1}{g} dg - \frac{1}{l} dl \right) \quad \dots (2)$$

where  $dn$ ,  $dg$ ,  $dl$  represent small changes in  $n$ ,  $g$ ,  $l$  respectively.

From (2), we get the number of beats lost or gained corresponding to the small variations in the values of length and gravity.

Particular Cases

**(i) When only  $l$  changes and  $g$  remains fixed**

$$\therefore dg = 0$$

$$\therefore \text{from (2), } dn = -\frac{n}{2} \cdot \frac{1}{l} dl \quad \dots (3)$$

If  $dl$  is positive, then from (3),  $dn$  is negative

i.e. if the length of the pendulum is increased and  $g$  remains same, then there is a decrease in the number of beats in any given time interval and hence the clock becomes slow.

Similarly if  $dl$  is negative, then from (3),  $dn$  is positive i.e. if the length of the pendulum is shortened and  $g$  remains same, then there is an increase in the number of beats in any given time interval and hence the clock runs fast.

**(ii) When only  $g$  changes and  $l$  remains fixed.**

$$\therefore dl = 0$$

$$\therefore \text{from (2), } dn = -\frac{n}{2} \cdot \frac{1}{g} dg$$

$\therefore$   $dn$  is positive if  $dg$  is positive i.e. if  $g$  increases, there is an increase in the number of beats in any given time interval and hence the clock runs fast. Similarly if  $g$  decreases, then there is a decrease in the number of beats in any given time interval and hence the clock becomes slow.

### 2.3.6.2 Pendulum at a height 'h'

When the pendulum is carried to a mountain at height  $h$  above the surface of earth.

We know that, by Newton's gravitational law,  $g = \frac{\mu}{r^2}$  where  $r$  is the distance of the point outside the surface of earth from the centre of the earth and  $\mu$  is constant.

$$\therefore \log g = \log \mu - 2 \log r$$

$$\Rightarrow \frac{1}{g} dg = 0 - \frac{2}{r} dr \Rightarrow \frac{1}{g} dg = -\frac{2}{r} dr$$

Here  $dr = h$

$$\therefore \frac{1}{g} dg = -2 \frac{h}{r} \quad \dots (1)$$

$$\text{Now } dn = \frac{n}{2} \frac{dg}{g}$$

$$\therefore dn = \frac{n}{2} \left( -\frac{2h}{r} \right) \text{ or } \therefore dn = -\frac{nh}{r} \quad [\because \text{of (1)}]$$

This equation shows that when a pendulum is carried to a high mountain, it loses number of beats in any given time interval and so the clock becomes slow.

### 2.3.6.3 Pendulum at a depth 'h'

When the pendulum is carried inside a mine at a depth  $h$  below the surface of earth.

We know that for the points inside the surface of the earth,  $g = \lambda r$

where  $r$  is the distance of the point from the centre of the earth and  $\lambda$  is constant.

$$\therefore \log g = \log \lambda + \log r$$

$$\Rightarrow \frac{1}{g} dg = 0 + \frac{1}{r} dr \Rightarrow \frac{1}{g} dg = \frac{1}{r} dr$$

Here  $dr = -h$

$$\therefore \frac{1}{g} dg = -\frac{h}{r}$$

$$\text{Now } dn = \frac{n}{2} \frac{dg}{g} \therefore dn = \frac{n}{2} \left( -\frac{h}{r} \right) \text{ or } \therefore dn = -\frac{nh}{2r} \quad [\because \text{of (2)}]$$

This equation shows that when a pendulum is carried to a deep mine, it loses number of beats in any given time interval and so the clock becomes slow.

### 2.3.7 Some Important Examples

**Example 1 :** A particle moves with an acceleration  $a$  given by  $a = -kv$  where  $v$  is the velocity of particle and  $k$  is constant. Express

(i)  $v$  in terms of  $t$       (ii)  $x$  in terms of  $t$       (iii)  $v$  in terms of  $x$

It is given that at  $t = 0$ ,  $v = v_0$  and  $x = 0$ .

**Sol.** (i) Here  $a = -kv \Rightarrow \frac{dv}{dt} = -kv$

Separating the variables,  $\frac{1}{v} dv = -k dt$

Integrating,  $\log v = -kt + c_1$  ... (1)

Initially  $t = 0$ ,  $v = v_0$ ,  $\therefore \log v_0 = 0 + c_1 \Rightarrow c_1 = \log v_0$

$\therefore$  from (1),  $\log v = -kt + \log v_0 \Rightarrow \log v - \log v_0 = -kt$

$\Rightarrow \log \left( \frac{v}{v_0} \right) = -kt \Rightarrow \frac{v}{v_0} = e^{-kt}$

$\Rightarrow v = v_0 e^{-kt}$ , which express  $v$  in term of  $t$ .

(ii)  $v = v_0 e^{-kt} \Rightarrow \frac{dx}{dt} = v_0 e^{-kt}$

Integrating w.r.t.  $t$ ,  $x = v_0 \frac{e^{-kt}}{-k} + c_2$  ... (2)

Initially  $t = 0$ ,  $x = 0$ ,  $\therefore 0 = -\frac{v_0}{k} + c_2 \Rightarrow c_2 = \frac{v_0}{k}$

$\therefore$  from (2),  $x = -\frac{v_0}{k} e^{-kt} + \frac{v_0}{k} \Rightarrow x = \frac{v_0}{k} (1 - e^{-kt})$

which expresses  $x$  in terms of  $t$ .

(iii) Now  $a = -kv \Rightarrow v \frac{dv}{dx} = -kv \Rightarrow \frac{dv}{dx} = -k$



Integrating w.r.t.  $x$ ,  $v = -kx + c_3$  ... (3)

Initially  $v = v_0$ ,  $x = 0$ ,  $\therefore v_0 = 0 + c_3 \Rightarrow c_3 = v_0$

$\therefore$  from (3),  $v = -kx + v_0$ , which expresses  $v$  in terms of  $x$ .

**Example 2 :** A particle starting from rest from the origin moves along  $x$ -axis; the

force at any time being  $\sin t + \frac{1}{(t+1)^2}$  per unit of mass. Show that after  $\frac{\pi}{2}$  seconds, the

particle is at a distance  $\pi - 1 - \log\left(\frac{\pi+2}{2}\right)$  units from the origin.

**Sol.** Let  $a$  be the acceleration of the particle at any time  $t$ .

Since force per unit mass is acceleration

$$\therefore a = \sin t + \frac{1}{(t+1)^2} \Rightarrow \frac{dv}{dt} = \sin t + (t+1)^{-2}$$

Integrating w.r.t.  $t$ ,  $v = -\cos t + \frac{(t+1)^{-1}}{-1} + c_1$

$$\text{or } v = -\cos t - \frac{1}{t+1} + c_1 \quad \dots (1)$$

Initially when  $t = 0$ ,  $v = 0$ ,  $\therefore 0 = -1 - 1 + c_1 \Rightarrow c_1 = 2$

$$\therefore \text{from (1), } v = -\cos t - \frac{1}{t+1} + 2 \Rightarrow \frac{dx}{dt} = -\cos t - \frac{1}{t+1} + 2$$

Integrating w.r.t.  $t$ ,  $x = -\sin t - \log(t+1) + 2t + c_2$  ... (2)

Initially when  $t = 0$ ,  $x = 0$ ,  $\therefore 0 = 0 - 0 + 0 + c_2 \Rightarrow c_2 = 0$

$\therefore$  from (2),  $x = -\sin t - \log(t+1) + 2t$

$$\text{When } t = \frac{\pi}{2}, x = -\sin \frac{\pi}{2} - \log\left(\frac{\pi}{2} + 1\right) + 2 \cdot \frac{\pi}{2}$$

$$= -1 - \log\left(\frac{\pi+2}{2}\right) + \pi$$

$$= \pi - 1 - \log\left(\frac{\pi+2}{2}\right) \text{ units from the origin.}$$

**Example 3 :** A point moving in a straight line with S.H.M. has velocities  $u$  and  $v$ ,

when its distances from the centre are  $a$  and  $b$ , prove period of motion is  $2\pi \sqrt{\frac{a^2 - b^2}{v^2 - u^2}}$ .

**Sol.** We know that  $V^2 = \mu (A^2 - x^2)$  ... (1)

where  $V$  is the velocity of the particle when its distance from centre is  $x$  and  $A$  is amplitude.

Now when  $x = a$ ,  $V = u$

$\therefore$  from (1),  $u^2 = \mu (A^2 - a^2)$  ... (2)

Again when  $x = b$ ,  $V = v$

$\therefore$  from (1),  $v^2 = \mu (A^2 - b^2)$  ... (3)

Subtracting (2) from (3), we get,

$$v^2 - u^2 = \mu (a^2 - b^2) \Rightarrow \mu = \frac{v^2 - u^2}{a^2 - b^2} \quad \dots (4)$$

$$\text{Period of motion} = \frac{2\pi}{\sqrt{\mu}} = \frac{2\pi}{\sqrt{\frac{v^2 - u^2}{a^2 - b^2}}} = 2\pi \sqrt{\frac{a^2 - b^2}{v^2 - u^2}}.$$

**Example 4 :** A particle moves with S.H.M. in a straight line. In the first second after starting from rest it travels a distance  $a$  and in the next second, it travels a

distance  $b$ . Prove that the amplitude of the motion is  $\frac{2a^2}{3a - b}$ .

**Sol.** Let  $O$  be the mean position and  $A'$  be the extreme position such that  $OA' = A$  is the amplitude.

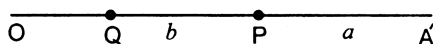

Since time is measured from extreme position

$$\therefore x = A \cos \sqrt{\mu} t \quad \dots (1)$$

where  $x$  is the distance from mean position.

When  $t = 1$ , distance  $A'P$  from extreme position =  $a$

$$\therefore x = A - a$$

$$\therefore \text{from (1), } A - a = A \cos \sqrt{\mu}$$

When  $t = 2$ , distance  $A'Q$  from extreme position =  $a + b$  ... (2)

$$\therefore x = A - a - b$$

$$\therefore \text{ from (1), } A - a - b = A \cos 2\sqrt{\mu}$$

$$\therefore A - a - b = A (2 \cos^2 \sqrt{\mu} - 1), \text{ as } \cos 2\theta = 2 \cos^2 \theta - 1$$

$$\therefore A - a - b = A \left[ 2 \left( \frac{A - a}{A} \right)^2 - 1 \right].$$

**Example 5 :** One end of an elastic string whose modulus of elasticity is  $\lambda$  and whose natural length is  $l$ , is tied to a fixed point on a smooth horizontal table and the other end is tied to a mass  $m$  lying on the table. The particle is pulled to a distance where the extension of the string becomes  $a$  and then let go ; show that

(i) the string becomes slack after a period of  $\frac{1}{2}\pi\sqrt{\frac{ml}{\lambda}}$

(ii) the period of the complete oscillation is  $2\left(\pi + \frac{2l}{a}\right)\sqrt{\frac{ml}{\lambda}}$ .

**Sol.** As we know, time period  $= \frac{2\pi}{\sqrt{\mu}} = 2\pi\sqrt{\frac{ml}{\lambda}}$

(i) the string becomes slack when the particle reaches at A.

$$\therefore \text{ required time} = \frac{1}{4} (\text{time period}) = \frac{1}{4} \times 2\pi\sqrt{\frac{ml}{\lambda}} = \frac{\pi}{2}\sqrt{\frac{ml}{\lambda}}$$

(ii) velocity at A = max. velocity of S.H.M.  $= \sqrt{\mu} a = \sqrt{\frac{\lambda}{ml}} \cdot a$

The particle moves under S.H.M. from B to A. At A, the strings becomes slack so that

the particle moves from A to A' (OA = OA' =  $l$ ) with constant velocity  $\sqrt{\frac{\lambda}{ml}} \cdot a$  attained

at A. Beyond A', the string again becomes stretched and the particle moves under S.H.M. to B' (A'B' = AB =  $a$ ) where it comes to rest. Then it returns to A' under the

same motion acquiring the constant velocity  $\sqrt{\frac{\lambda}{ml}} \cdot a$ . It moves from A' to A with

constant velocity and then from A to B under S.H.M.

∴ time from B to A, A' to B' to A', A to B

$$= \text{periodic time of S.H.M.} = \frac{2\pi}{\sqrt{\mu}} = 2\pi \sqrt{\frac{ml}{\lambda}}$$

Time from A to A' and from A' to A

$$= \text{time to describe distance } 4l \text{ with velocity } \sqrt{\frac{\lambda}{ml}} \cdot a$$

$$= \frac{\text{distance}}{\text{speed}} = \frac{4l}{a} \sqrt{\frac{ml}{\lambda}}$$

$$\therefore \text{total time} = 2\pi \sqrt{\frac{ml}{\lambda}} + \frac{4l}{a} \sqrt{\frac{ml}{\lambda}} = \left(2\pi + \frac{4l}{a}\right) \sqrt{\frac{ml}{\lambda}}$$

$$= 2 \left( \pi + \frac{2l}{a} \right) \sqrt{\frac{ml}{\lambda}}.$$

**Example 6 :** A clock with a second's pendulum loses 20 seconds per day at a place where acceleration due to gravity is 9.8 m/sec<sup>2</sup>. Find what change is necessary to make it accurate in (i) length (ii) gravity.

**Sol.** Here  $n = 24 \times 60 \times 60 = 86400$ ,  $dn = -20$

$$(i) \quad \text{Now } 1 = \pi \sqrt{\frac{l}{g}} \Rightarrow l = \frac{g}{\pi^2}$$

$$\text{Also } dn = -\frac{n}{2} \frac{dl}{l} \Rightarrow -20 = -\frac{86400}{2} \cdot \frac{dl}{g/\pi^2}$$

$$\Rightarrow dl = \frac{40g}{86400\pi^2} = \frac{40 \times 981}{86400 \times 9.87} \text{ cm} = 0.05 \text{ cm}$$

$$(ii) \quad \text{Now } dn = \frac{n}{2} \frac{dg}{g} \Rightarrow 2 \frac{dn}{n} = \frac{dg}{g}$$

$$\Rightarrow 1 + 2 \frac{dn}{n} = 1 + \frac{dg}{g} \Rightarrow \frac{n + 2 dn}{n} = \frac{g + dg}{g}$$

$$\Rightarrow \frac{86400 + 2(-20)}{86400} = \frac{9.8}{8}$$

$$\Rightarrow g = \frac{86400 \times 9.8}{86360} = 9.8045 \text{ m/sec}^2$$

$\therefore$   $g$  should be increased by .8045 cm/sec<sup>2</sup>.

**Example 7 :** A pendulum which beats seconds at the surface of the earth is carried to the top of a mountain 5 km high, how many seconds will it lose or gain per day? What correction in its present length be made so that it may beat seconds at the top of the mountain ?

**Sol.** Here  $n = 24 \times 60 \times 60 = 86400$ ,  $h = 5$  km,  $r = 6400$  km

$$\text{Now } dn = -\frac{nh}{r} \Rightarrow dn = -\frac{86400 \times 5}{6400} = -67 \frac{1}{2} \text{ seconds}$$

$\therefore$  clock will lose  $67 \frac{1}{2}$  seconds per day on the top of the mountain.

We have

$$dn = \frac{n}{2} \left( \frac{dg}{g} - \frac{dl}{l} \right)$$

$$\Rightarrow 0 = \frac{n}{2} \left( \frac{dg}{g} - \frac{dl}{l} \right) \quad [\because dn = 0 \text{ as the pendulum is to keep correct time}]$$

$$\Rightarrow \frac{dl}{l} = \frac{dg}{g} = -\frac{2h}{r} \quad \left[ \because \frac{dg}{g} = -\frac{2h}{r} \right]$$

$$\Rightarrow dt = -\frac{2h}{r} \cdot l = -2 \times \frac{5}{6400} l = -\frac{1}{640} l$$

$\therefore$  to keep correct time at the top of mountain, the present length of the pendulum

must be shortened by  $\frac{1}{640}$  of itself.

### 2.3.8 Summary

In this lesson, we have reviewed Newton's laws of motions. We have focused on various physical terms involved during motion of two particles connected by a string, motion along a smooth inclined plane under the action of gravity and constrained motion along a smooth inclined plane. Moreover, we have also stated Newton's law of gravitational attraction and solved various examples based upon it.

### 2.3.9 Key Concepts

Simple harmonic motion, Periodic motion, Gravitational constant, Centre of attraction or Centre of oscillation or Mean position or Position of equilibrium, Amplitude, Maximum and minimum velocities, Maximum and minimum acceleration, Elastic string, Horizontal elastic string, Simple pendulum, Second pendulum.

### 2.3.10 Long Questions

1. A particle starts from A and moves in a straight line AO ( $=a$ ) with an acceleration which is directed towards O and varies inversely as the square of the distance from O. Show that the particle arrives at O with an infinite velocity after time

$$\frac{\pi}{2} \cdot \frac{a^{3/2}}{\sqrt{2} \mu}, \mu \text{ being the constant of variation.}$$

2. A point moving with S.H.M. has a period of oscillation of  $\pi$  seconds and its greatest acceleration is  $5 \text{ m/sec}^2$ . Find the amplitude and the velocity when the particle is at a distance of 1 metre from the centre of oscillation.
3. A particle moves under S.H.M., the amplitude of motion being 1 metre. It is given that the magnitude of velocity is  $2 \text{ m/sec}$  when the particle is displaced  $\frac{3}{5}$  metre from the position of maximum velocity. Determine the magnitude of acceleration of the particle for this position.
4. A point moving in a straight line with S.H.M. has velocities  $v_1$  and  $v_2$  when its distances from the centre are  $x_1$  and  $x_2$ . Show that the period of motion is

$$2\pi \sqrt{\frac{x_1^2 - x_2^2}{v_2^2 - v_1^2}}.$$

5. A particle moves along a straight line and its velocity at any time  $t$  is given by the equation  $v = \pi \cos \frac{\pi}{2}t$ . Show that the motion is S.H.M. and find its time period. Also compute the total distance covered by the particle during the interval from  $t = 0$  to  $t = 3$  seconds.

**2.3.11 Short Questions**

1. The force acting on a particle varies with time according to the relation  $p = 12mt^2$ , where  $m$  is the mass of the particle. Find the velocity and the distance travelled after 2 secs, knowing that  $x = 0$  and  $v = -4.0$  m/sec when  $t = 0$ .
2. A particle moves in a straight and is subjected to an acceleration which varies as the square of its speed. When  $t = 2$  secs,  $x = 0$  and  $v = \frac{1}{2}$  m/sec and when  $t = 4$  secs,  $v = 1$  m/sec. Determine the initial velocity and the maximum time for which motion is finite.
3. State Newton's law of gravitational attraction.
4. If the time of one complete oscillation of a simple pendulum is 20 seconds, find the length of the pendulum.
5. Calculate the number of beats lost per day if the length of second's pendulum is increased by  $\frac{1}{1000}$  of itself.
6. A clock which keeps correct time at the surface of the earth loses 10 seconds a day when taken down a mine, find its depth. The radius of the earth being taken as  $64 \times 10^5$  metres.

**2.3.12 Suggested Readings**

1. S.L. Loney : The Elements of Statics and Dynamics, 5th Edition, Cambridge University Press, 1947.

## **DYNAMICS-IV**

- 2.4.1 Objectives**
- 2.4.2 Introduction**
- 2.4.3 Projectile Motion**
- 2.4.4 Projectiles on an Inclined Plane**
- 2.4.5 Some Important Examples**
- 2.4.6 Summary**
- 2.4.7 Key Concepts**
- 2.4.8 Long Questions**
- 2.4.9 Short Questions**
- 2.4.10 Suggested Readings**

### **2.4.1 Objectives**

In the previous unit, we have discussed the motion of a particle along a straight line i.e. rectilinear motion in which position of the particle is determined by a single displacement along the straight line. In this unit, we will focus on the curvilinear motion i.e. motion of a particle in plane where position of the particle will be determined by two distance measurements in plane. If we are working in rectangular co-ordinate system, then the two distances  $x$ ,  $y$  are measured as to X-axis OX and Y-axis OY, where O is the fixed origin. If we are working in polar co-ordinate system then the position P of the particle is determined by OP ( $=r$ ) i.e. distance of the particle from a fixed origin O and the angle  $\theta$  which OP makes with the fixed line OX in the plane.

From this lesson, the students would be able to discuss in detail about the projectile motion and its physical terms associated.

### **2.4.2 Introduction**

**Art 1 :** Find the expressions for velocity and acceleration of a particle moving in a plane in rectangular co-ordinate system.

**Proof :** Let the particle be moving along the curve AB and let it move from the



position P ( $x, y$ ) at time  $t$  to the neighbouring point ( $x + \delta x, y + \delta y$ ) at  $t + \delta t$ .

The displacement PQ may be represented by its components PN and NQ parallel to the axes.

The displacement of the particle parallel to OX in time  $\delta t$   
 $= PN = \delta x$

$$\therefore \text{resolved part of the velocity parallel to OX} = \lim_{\delta t \rightarrow 0} \frac{\delta x}{\delta t} = \frac{dx}{dt}$$

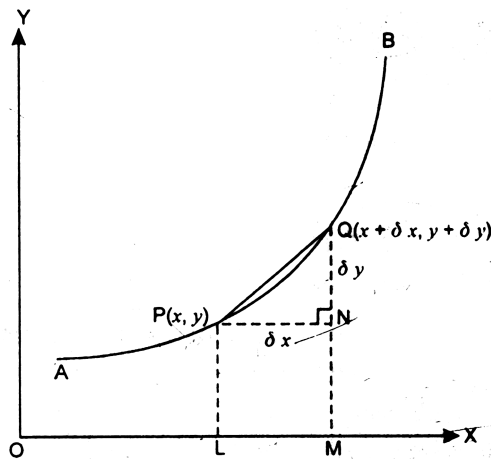

Similarly the resolved part of the velocity parallel to OY  $= \lim_{\delta t \rightarrow 0} \frac{\delta y}{\delta t} = \frac{dy}{dt}$

If  $V$  is the resultant velocity making an angle  $\theta$  with OX, then

$$V \cos \theta = \frac{dx}{dt} \quad \dots (1)$$

$$\text{and } V \sin \theta = \frac{dy}{dt} \quad \dots (2)$$

Squaring and adding (1) and (2), we get,

$$V^2 (\cos^2 \theta + \sin^2 \theta) = \left(\frac{dx}{dt}\right)^2 + \left(\frac{dy}{dt}\right)^2 \text{ or } V^2 = \left(\frac{dx}{dt}\right)^2 + \left(\frac{dy}{dt}\right)^2$$

$$\therefore V = \sqrt{\left(\frac{dx}{dt}\right)^2 + \left(\frac{dy}{dt}\right)^2}$$

Dividing (2) by (1), we get,

$$\tan \theta = \frac{\frac{dy}{dt}}{\frac{dx}{dt}} = \frac{dy}{dx} = \tan \phi, \text{ where } \phi \text{ is the angle which the tangent to the curve at P makes}$$

with x-axis.

Hence the velocity at any point on the path acts along the tangent to the path at the point.

Now let  $u, v$  be the resolved part of the velocity of the particle parallel to the axes at time  $t$  and  $u + \delta u, v + \delta v$  be the resolved parts of the velocity at time  $t + \delta t$ . Then acceleration along OX

$$\begin{aligned} &= \lim_{\delta t \rightarrow 0} \frac{\text{Change in velocity in time } \delta t \text{ along OX}}{\delta t} \\ &= \lim_{\delta t \rightarrow 0} \frac{(u + \delta u) - u}{\delta t} = \lim_{\delta t \rightarrow 0} \frac{\delta u}{\delta t} = \frac{du}{dt} = \frac{d}{dt} \left( \frac{dx}{dt} \right) = \frac{d^2x}{dt^2} \end{aligned}$$

and acceleration along OY

$$\begin{aligned} &= \lim_{\delta t \rightarrow 0} \frac{\text{Change in velocity in time } \delta t \text{ along OY}}{\delta t} \\ &= \lim_{\delta t \rightarrow 0} \frac{(v + \delta v) - v}{\delta t} = \lim_{\delta t \rightarrow 0} \frac{\delta v}{\delta t} = \frac{dv}{dt} = \frac{d}{dt} \left( \frac{dy}{dt} \right) = \frac{d^2y}{dt^2} \end{aligned}$$

$$\therefore \text{resultant acceleration} = \sqrt{\left( \frac{d^2x}{dt^2} \right)^2 + \left( \frac{d^2y}{dt^2} \right)^2}$$

$$\text{and it acts at an angle } \tan^{-1} \left( \frac{\frac{d^2y}{dt^2}}{\frac{d^2x}{dt^2}} \right) \text{ with OX}$$

**Note :**  $\frac{d^2x}{dt^2} = u \frac{du}{dx}, \frac{d^2y}{dt^2} = v \frac{dv}{dy}$

### Equation of Motion of a Particle in a Plane

Let X and Y be the sum of resolved parts of the forces acting on the particle of mass m parallel to OX and OY respectively.

∴ the equation of motion are

$$m \frac{d^2x}{dt^2} = X \text{ and } m \frac{d^2y}{dt^2} = Y$$

### 2.4.3 Projectile Motion

A projectile may be defined as a body which is small enough to be regarded as a particle and which is projected in a direction oblique to the direction of gravity.

Some basic terms concerned with projectile motion are discussed below :

1. **Trajectory :** It is the path traced by the projectile.
2. **Velocity of Projection :** It is the velocity with which the particle is projected.
3. **Angle of Projection :** It is the angle which the direction of motion makes with the horizontal.
4. **Range :** It is the distance measured between the point of projection and the point where the projectile hits a given plane through the point of projection.  
If the given plane is horizontal, then range is called horizontal range.
5. **Time of Flight :** It is the time taken to complete a particular range.

**Art 2 :** A particle of mass 'm' is projected from a fixed point with velocity 'u' in a

direction making an angle  $\alpha \left( \neq \frac{\pi}{2} \right)$  with the horizontal. Neglecting air resistance,

find its motion and

- (i) Show that its path is a parabola,
- (ii) Find latus rectum, vertex, focus and height of direction of the parabola,
- (iii) Find time of flight, horizontal range, maximum horizontal range, direction of projection for a given horizontal range, greatest height attained.

**Proof :** Let O, the point of projection, be taken as the origin and let the horizontal and the vertical lines through O be taken as the axes of x and y.

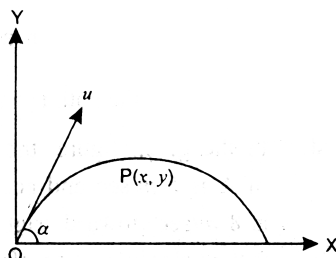

Let P (x, y) be the position of the particle after time t.

Resolved part of the acceleration at P along OX =  $\frac{d^2x}{dt^2}$

Resolved part of the acceleration at P along OY =  $\frac{d^2y}{dt^2}$

During the motion of the projectile, the only force acting on it is its weight  $m g$  acting vertically downwards.

$\therefore$  the equations of motion in the horizontal and vertical directions are

$$m \frac{d^2x}{dt^2} = 0 \text{ and } m \frac{d^2y}{dt^2} = -mg$$

$$\text{or } \frac{d^2x}{dt^2} = 0 \quad \dots (1)$$

$$\text{and } \frac{d^2y}{dt^2} = -g \quad \dots (2)$$

Integrating (1) and (2) w.r.t. t, we get,

$$\frac{dx}{dt} = c_1 \quad \dots (3)$$

$$\text{and } \frac{dy}{dt} = -gt = c_2 \quad \dots (4)$$

where  $c_1, c_2$  are constants of integration.

Initially at O, when  $t = 0$ ,  $\frac{dx}{dt} = u \cos \alpha$ ,  $\frac{dy}{dt} = u \sin \alpha$

$\therefore$  from (3) and (4), we get,  $c_1 = u \cos \alpha$ ,  $c_2 = u \sin \alpha$

$$\therefore \text{ from (3), } \frac{dx}{dt} = u \cos \alpha \quad \dots (5)$$

$$\text{and from (4), } \frac{dy}{dt} = u \sin \alpha - gt \quad \dots (6)$$

From (5), it is clear that the horizontal component of velocity will remain constant and equal to  $u \cos \alpha$  throughout the motion.

Equations (5) and (6) give the components of velocity in the horizontal and vertical directions at any time  $t$ .

Integrating (5) and (6), w.r.t  $t$ , we get, ... (7)

$$x = u \cos \alpha \cdot t + A$$

$$\text{and } y = u \sin \alpha \cdot t - \frac{1}{2}gt^2 + B \quad \dots (8)$$

Initially at O, when  $t = 0$ ,  $x = 0$ ,  $y = 0$

$\therefore$  from (7) and (8), we get,  $A = 0$ ,  $B = 0$

$$\therefore \text{ from (7) } x = u \cos \alpha \cdot t \quad \dots (9)$$

$$\text{and from (8), } y = u \sin \alpha \cdot t - \frac{1}{2}gt^2 \quad \dots (10)$$

Equations (9) and (10) given the position of the particle after time  $t$ .

Now to obtain the equation of path traced out by the particle, we eliminate  $t$  from (9) and (10).

$$\text{From (9), } t = \frac{x}{u \cos \alpha}$$

Putting this value of  $t$  in (10), we get,

$$y = u \sin \alpha \left( \frac{x}{u \cos \alpha} \right) - \frac{1}{2}g \left( \frac{x}{u \cos \alpha} \right)^2$$

$$\text{or } y = x \tan \alpha - \frac{1}{2} \frac{gx^2}{u^2 \cos^2 \alpha} \quad \dots (11)$$

which is the equation of the path of the projectile.

(i) Multiplying both sides of (11) by  $-\frac{2u^2 \cos^2 \alpha}{g}$ , we get,

$$-\frac{2u^2 \cos^2 \alpha}{g} y = -\frac{2u^2 \cos \alpha \sin \alpha}{g} (x) + x^2$$

$$\therefore x^2 - \frac{2u^2 \sin \alpha \cos \alpha}{g} x = -\frac{2u^2 \cos^2 \alpha}{g} y$$

Adding  $\left(\frac{u^2 \sin \alpha \cos \alpha}{g}\right)^2$  to both sides,

$$x^2 - \frac{2u^2 \sin \alpha \cos \alpha}{g} x + \frac{u^2 \sin^2 \alpha \cos^2 \alpha}{g} = -\frac{2u^2 \cos^2 \alpha}{g} y + \frac{u^2 \sin^2 \alpha \cos^2 \alpha}{g^2}$$

$$\text{or } \left(x - \frac{u^2 \sin \alpha \cos \alpha}{g}\right)^2 = -\frac{2u^2 \cos^2 \alpha}{g} \left(y - \frac{u^2 \sin^2 \alpha}{2g}\right)$$

which is a parabola of the form  $(x-h)^2 = -l(y-k)$

(ii) Clearly Vertex of the parabola is  $(h, k)$

$$\text{i.e. } \left(\frac{u^2 \sin \alpha \cos \alpha}{g}, \frac{u^2 \sin^2 \alpha}{2g}\right)$$

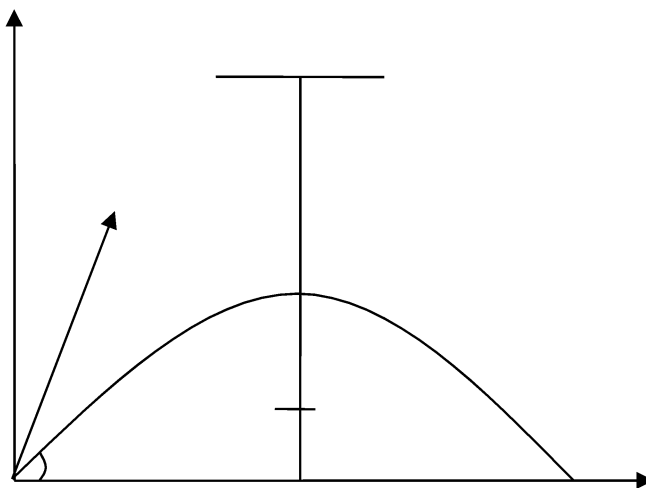

Latus rectum

$$= \frac{2u^2 \cos^2 \alpha}{g} = \frac{2}{g} (u \cos \alpha)^2$$

$$= \frac{2}{g} (\text{horizontal component of velocity})^2$$

Focus

$$\text{Abscissa of focus S} = \text{OM} = \text{abscissa of vertex A} = \frac{u^2 \sin \alpha \cos \alpha}{g}$$

$$\text{Ordinate of focus S} = \text{MS} = \text{MA} - \text{SA}$$

$$= \text{ordinate of vertex A} - \frac{1}{4} (\text{latus rectum})$$

$$= \frac{u^2 \sin^2 \alpha}{g} - \frac{1}{4} \times \frac{2u^2 \cos^2 \alpha}{g} = -\frac{u^2}{2g} (\cos^2 \alpha - \sin^2 \alpha)$$

$$= -\frac{u^2 \cos 2\alpha}{2g}$$

$$\therefore \text{focus S is } \left( \frac{u^2 \sin \alpha \cos \alpha}{g}, -\frac{u^2 \cos 2\alpha}{2g} \right) \text{ or } \left( \frac{u^2 \sin 2\alpha}{2g}, -\frac{u^2 \cos 2\alpha}{2g} \right)$$

### Height of the directrix

$$\text{Height of the directrix} = \text{MZ} = \text{MA} + \text{AZ}$$

$$= \text{ordinate of vertex A} + \frac{1}{4} (\text{latus rectum})$$

$$= \frac{u^2 \sin^2 \alpha}{g} + \frac{1}{4} \times \frac{2u^2 \cos^2 \alpha}{g} = -\frac{u^2}{2g} (\sin^2 \alpha + \cos^2 \alpha)$$

$$= \frac{u^2}{2g}$$

### (iii) Time of Flight :

Now time of flight, T, is the time which the particle takes in reaching the horizontal plane through the point of projection.

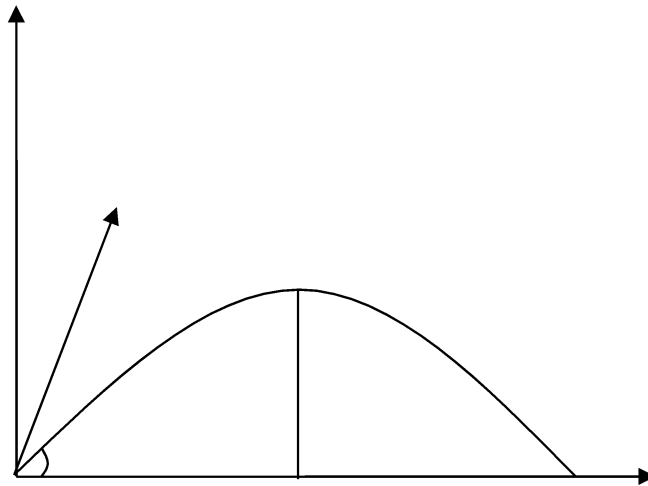

Putting  $y = 0$  in (10), we get,

$$0 = u \sin \alpha \cdot t - \frac{1}{2} g t^2 \quad \text{or} \quad t \left( u \sin \alpha - \frac{1}{2} g t \right) = 0$$

$$\therefore \quad t = 0, \frac{2u \sin \alpha}{g}$$

But  $t = 0$ , corresponds the time when the particle is at the point of projection O

$$\therefore \quad T = \frac{2u \sin \alpha}{g}$$

### **Horizontal Range :**

Let R is the horizontal range OB

$\therefore$  R = the horizontal distance described by the particle in time of flight T.

$$\therefore \quad R = (u \cos \alpha) \cdot t = u \cos \alpha \cdot \frac{2u \sin \alpha}{g} = \frac{2u^2 \sin \alpha \cos \alpha}{g} = \frac{u^2}{g} \sin 2\alpha .$$

### **Maximum Horizontal Range :**

The horizontal range  $R = \frac{u^2 \sin 2\alpha}{g}$  is maximum when  $\sin 2\alpha$  is maximum i.e., when



$$\sin 2\alpha = 1$$

$$\text{i.e., when } 2\alpha = \frac{\pi}{2} \text{ i.e., when } \alpha = \frac{\pi}{4}$$

$\therefore$  the horizontal range is maximum when the angle of projection is  $\frac{\pi}{4}$

$$\text{and max. horizontal range} = \frac{u^2}{g}.$$

### Direction of Projection :

$$\text{Since } \frac{u^2}{g} \sin 2\left(\frac{\pi}{2} - \alpha\right) = \frac{u^2}{g} \sin(\pi - 2\alpha) = \frac{u^2 \sin 2\alpha}{g}$$

angles  $\frac{\pi}{2} - \alpha$  and  $\alpha$  give the same range.

Hence with a given velocity of projection, to have a particular range, there are two directions of projection which are such that the inclination of the one with the horizontal is the same as that of the other with the vertical i.e., they are equally inclined to the direction of the maximum range.

### Greatest Height Attained :

Greatest height attained = MA = ordinate of vertex A

$$= \frac{u^2 \sin^2 \alpha}{2g}.$$

**Art 3 :** Find the velocity and direction of motion of a projectile after a given time  $t$ .

**Proof :** Let  $u$  be the velocity of projection and  $\alpha$  the angle of projection. Let particle be at P after time  $t$ . Let  $v$  be its velocity at P ( $x, y$ ) and  $\theta$  the angle which the direction of velocity at P makes with horizontal. Therefore, we have,

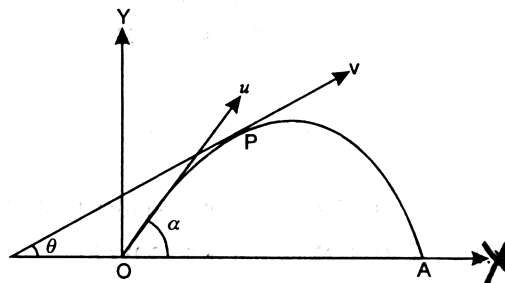

$$x = u \cos \alpha \cdot t$$

.... (1)

$$\text{and } y = u \sin \alpha \cdot t - \frac{1}{2}gt^2 \quad \dots (2)$$

Now  $v \cos \theta =$  horizontal component of velocity after a time  $t$

$$= \frac{dx}{dt} = u \cos \alpha \quad [\because \text{of (1)}]$$

$$\therefore v \cos \theta = u \cos \alpha \quad \dots (3)$$

and  $v \sin \theta =$  vertical component of velocity after a time  $t$

$$= \frac{dy}{dt} = u \sin \alpha - gt \quad [\because \text{of (2)}]$$

$$\therefore v \sin \theta = u \sin \alpha - gt \quad \dots (4)$$

Squaring and adding (3) and (4), we get,

$$v^2 \cos^2 \theta + v^2 \sin^2 \theta = u^2 \cos^2 \alpha + (u \sin \alpha - gt)^2$$

$$\text{or } v^2 (\cos^2 \theta + \sin^2 \theta) = u^2 (\cos^2 \alpha + \sin^2 \alpha) - 2u \sin \alpha \cdot gt + g^2 t^2$$

$$\text{or } v^2 = u^2 - 2ug \sin \alpha \cdot t + g^2 t^2 \text{ or } v = \sqrt{u^2 - 2ug \sin \alpha \cdot t + g^2 t^2}$$

which gives the magnitude of velocity at any time  $t$ .

Dividing (4) by (3), we get,

$$\tan \theta = \frac{u \sin \alpha - gt}{u \cos \alpha} \text{ i.e. } \theta = \tan^{-1} \left( \frac{u \sin \alpha - gt}{u \cos \alpha} \right)$$

which gives the direction of motion after time  $t$ .

**Cor.** Show that the magnitude of velocity at any point of a projectile is the same as would be acquired by a particle in falling freely a vertical distance from the level of the directrix to that point.

**Sol.** (Do Yourself)

**Art 4 :** Show that there are in general two directions of projection for a projectile to hit a given point with a given velocity of projection.

Also find the least velocity of projection to hit a given point.

**Proof :** Let  $u$  be the velocity of projection and  $\alpha$  the angle of projection.

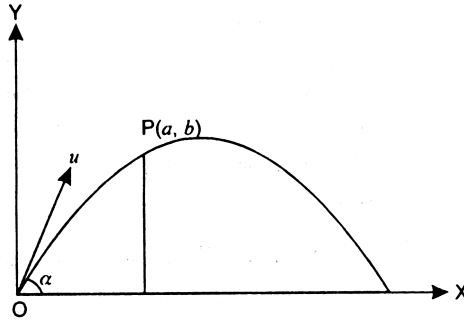

The equation of the trajectory is

$$y = x \tan \alpha - \frac{gx^2}{2u^2 \cos^2 \alpha} \quad \dots (1)$$

Let P (a, b) the given point. Then P (a, b) lies on (1) as projectile hits P.

$$\therefore b = a \tan \alpha - \frac{ga^2}{2u^2 \cos^2 \alpha}$$

$$\text{or } b = a \tan \alpha - \frac{ga^2}{2u^2} \sec^2 \alpha$$

$$\Rightarrow b = a \tan \alpha - \frac{ga^2}{2u^2} (1 + \tan^2 \alpha)$$

$$\Rightarrow 2bu^2 = 2au^2 \tan \alpha - ga^2 - ga^2 \tan^2 \alpha$$

$$\Rightarrow ga^2 \tan^2 \alpha - 2u^2 a \tan \alpha + (ga^2 + 2bu^2) = 0 \quad \dots (2)$$

This is a quadratic in  $\tan \alpha$  giving us two values of  $\tan \alpha$  and consequently two values of  $\alpha$ , corresponding to each of which we get a direction of projection.

The hitting is possible when  $\alpha$  is real i.e., if the roots of (2) are real

$$\text{i.e., if disc} \geq 0$$

$$\text{i.e., if } (-2u^2 a)^2 - 4.(ga^2)(ga^2 + 2bu^2) \geq 0$$

$$\text{i.e., if } u^4 a^2 - g^2 a^4 - 2ba^2 gu^2 \geq 0$$

$$\text{i.e., if } u^4 - g^2 a^2 - 2gbu^2 \geq 0$$

$$\text{i.e., if } u^4 - 2bgu^2 \geq a^2 g^2$$

$$\text{i.e., if } u^4 - 2bgu^2 + b^2 g^2 \geq a^2 g^2 + b^2 g^2$$

$$\text{i.e., if } (u^2 - bg)^2 \geq g^2(a^2 + b^2)$$

$$\text{i.e., if } u^2 - bg \geq g\sqrt{a^2 + b^2}$$

$$\text{i.e., if } u^2 \geq bg + g\sqrt{a^2 + b^2}$$

$$\text{i.e., if } u^2 \geq g\left(b + \sqrt{a^2 + b^2}\right)$$

$$\therefore \text{ least velocity of projection to hit } (a, b) \text{ is } \sqrt{g\left(b + \sqrt{a^2 + b^2}\right)}.$$

**Art 5 :** Find the equation giving the two times corresponding to the two directions of projection for a projectile to hit a given point with a given velocity of projection. Show that product of times is

(i) independent of the initial velocity

(ii) equal to  $\frac{2PQ}{g}$  where P is the point of projection and Q, the point to be hit.

**Proof :** Try Yourself.

#### 2.4.4 Projectiles on an Inclined Plane

**Art 6 :** A particle is projected with velocity 'u' making an angle ' $\alpha$ ' with the horizontal, up an inclined plane of inclination  $\beta$  with the horizon and strikes it at a point P. Find (i) range on the plane, (ii) maximum range (iii) time of flight (iv) velocity of the particle at P (v) angle which this velocity makes with the horizontal.

**Proof :** Take O, the point of projection, as origin; horizontal and vertical lines through O as axes. Let P be the point where the particle strikes the inclined plane. Let OP = R so that P is  $(R \cos \beta, R \sin \beta)$

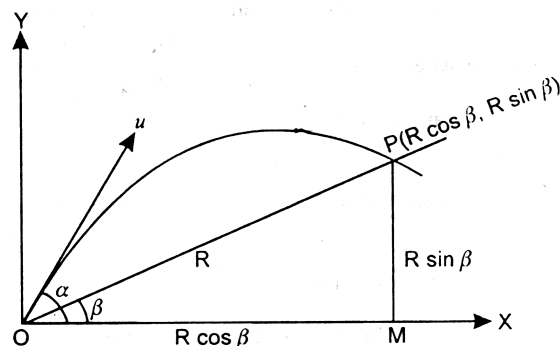

(i) The equation of the path of projectile is

$$y = x \tan \alpha - \frac{gx^2}{2u^2 \cos^2 \alpha}$$

$\therefore$  A ( $R \cos \beta$ ,  $R \sin \beta$ ) lies on it

$$\therefore R \sin \beta = R \cos \beta \cdot \tan \alpha - \frac{gR^2 \cos^2 \beta}{2u^2 \cos^2 \alpha}$$

$$\Rightarrow \sin \beta = R \cos \beta \cdot \tan \alpha - \frac{gR \cos^2 \beta}{2u^2 \cos^2 \alpha}$$

$$\Rightarrow \frac{gR \cos^2 \beta}{2u^2 \cos^2 \alpha} = \cos \beta \cdot \frac{\sin \alpha}{\cos \alpha} - \sin \beta$$

$$\Rightarrow \frac{gR \cos^2 \beta}{2u^2 \cos \alpha} = \frac{\sin \alpha \cos \beta - \cos \alpha \sin \beta}{\cos \alpha}$$

$$\Rightarrow \frac{gR \cos^2 \beta}{2u^2 \cos^2 \alpha} = \frac{\sin(\alpha - \beta)}{\cos \alpha}$$

$$\Rightarrow R = \frac{2u^2 \sin(\alpha - \beta) \cos \alpha}{g \cos^2 \beta}$$

which gives the range on the plane.

$$(ii) \quad \text{Now } R = \frac{2u^2 \sin(\alpha - \beta) \cos \alpha}{g \cos^2 \beta} = \frac{u^2}{g \cos^2 \beta} [2 \sin(\alpha - \beta) \cos \alpha]$$

$$= \frac{u^2}{g \cos^2 \beta} [\sin(2\alpha - \beta) + \sin(-\beta)] = \frac{u^2}{g \cos^2 \beta} [\sin(2\alpha - \beta) - \sin \beta],$$

where  $u$ ,  $g$ ,  $\beta$  are constants.

$\therefore$   $R$  is maximum when  $\sin(2\alpha - \beta)$  is maximum i.e. when  $\sin(2\alpha - \beta) = 1$  and this is so when  $2\alpha - \beta = \frac{\pi}{2}$  or  $\alpha = \frac{\pi}{4} + \frac{\beta}{2}$ , which gives the angle of projection for maximum range up the plane.

$$\therefore \text{max. range} = \frac{u^2}{g \cos^2 \beta} (1 - \sin \beta) = \frac{u^2 (1 - \sin \beta)}{g (1 - \sin^2 \beta)} = \frac{u^2}{g (1 + \sin \beta)}$$

(iii) Let the particle strike the plane after time T

$\therefore$  OM = horizontal distance covered in time T =  $u \cos \alpha \cdot T$

$$\Rightarrow R \cos \beta = u \cos \alpha \cdot T \Rightarrow T = \frac{R \cos \beta}{u \cos \alpha}$$

$$\Rightarrow T = \frac{\cos \beta}{u \cos \alpha} \cdot \frac{2u^2 \sin(\alpha - \beta) \cos \alpha}{g \cos^2 \beta}$$

$$\Rightarrow T = \frac{2u \sin(\alpha - \beta)}{g \cos \beta}.$$

### 2.4.5 Some Important Examples

**Example 1 :** The velocity at the maximum height of projectile is half of its initial

velocity  $u$ . Prove that the range on the horizontal plane is  $\frac{u^2 \sqrt{3}}{2g}$ .

**Sol.** We know that the vertical component of velocity vanishes at the maximum height

$$\therefore \text{velocity at the maximum height of a particle} \\ = \text{horizontal component of velocity} = u \cos \alpha$$

where  $\alpha$  is the angle of projection.

From the given condition.

$$u \cos \alpha = \frac{1}{2} u \Rightarrow \cos \alpha = \frac{1}{2} \Rightarrow \sin \alpha = \sqrt{1 - \cos^2 \alpha} = \sqrt{1 - \frac{1}{4}} = \frac{\sqrt{3}}{2}$$

$$\therefore \text{horizontal range} = \frac{2u^2 \sin \alpha \cos \alpha}{g} = \frac{2u^2 \times \frac{1}{2} \times \frac{\sqrt{3}}{2}}{g} = \frac{u^2 \sqrt{3}}{2g}.$$

**Example 2 :** Two bodies are projected from the same point in directions making angles  $\alpha_1$  and  $\alpha_2$  with the horizontal and strike at the same point on the horizontal plane through the point of projection. If  $t_1$  and  $t_2$  be their times of flight, show that

$$\frac{t_1^2 - t_2^2}{t_1^2 + t_2^2} = \frac{\sin(\alpha_1 - \alpha_2)}{\sin(\alpha_1 + \alpha_2)}.$$

**Sol.** Let  $u$  be the velocity of projection. The angles of projection are  $\alpha_1$  and  $\alpha_2$ .

$$\therefore \alpha_1 + \alpha_2 = \frac{\pi}{2} \quad \dots (1)$$

$$\text{Now } t_1 = \frac{2u \sin \alpha_1}{g}, t_2 = \frac{2u \sin \alpha_2}{g}$$

$$\therefore \frac{t_1^2}{t_2^2} = \frac{\sin^2 \alpha_1}{\sin^2 \alpha_2}$$

by componendo an dividendo, we get,

$$\frac{t_1^2 - t_2^2}{t_1^2 + t_2^2} = \frac{\sin^2 \alpha_1 - \sin^2 \alpha_2}{\sin^2 \alpha_1 + \sin^2 \alpha_2}$$

$$= \frac{\sin(\alpha_1 + \alpha_2) \sin(\alpha_1 - \alpha_2)}{\sin^2 \alpha_1 + \sin^2 \left(\frac{\pi}{2} - \alpha_1\right)} = \frac{\sin \frac{\pi}{2} \sin(\alpha_1 - \alpha_2)}{\sin^2 \alpha_1 + \cos^2 \alpha_1}$$

$$= \sin(\alpha_1 - \alpha_2) = \frac{\sin(\alpha_1 - \alpha_2)}{\sin(\alpha_1 + \alpha_2)} \quad \left[ \because \sin(\alpha_1 + \alpha_2) = \sin \frac{\pi}{2} = 1 \right]$$

$$\therefore \frac{t_1^2 - t_2^2}{t_1^2 + t_2^2} = \frac{\sin(\alpha_1 - \alpha_2)}{\sin(\alpha_1 + \alpha_2)}.$$

**Example 3 :** Two seconds after its projection, a projectile is travelling in a direction inclined at  $30^\circ$  to the horizon. After one more second, it is traveling horizontally. Determine the magnitude and direction of its initial velocity.

**Sol.** Let  $u$  be the velocity of projection and  $\alpha$  the angle of projection. After its projection from  $O$ , let the particle after two seconds be at  $P$  and after the end of 3 second the particle be at  $Q$ , the highest point of the trajectory.

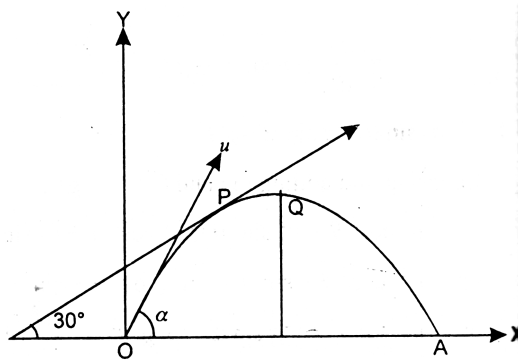

At P,  $\theta = 30^\circ$ ,  $t = 2$

$$\therefore \tan 30^\circ = \frac{u \sin \alpha - g \cdot 2}{u \cos \alpha} \quad \left[ \because \tan \theta = \frac{u \sin \alpha - gt}{u \cos \alpha} \right]$$

$$\Rightarrow \frac{1}{\sqrt{3}} = \frac{u \sin \alpha - g \cdot 2}{u \cos \alpha} \Rightarrow u \cos \alpha = \sqrt{3} (u \sin \alpha - 2g) \quad \dots (1)$$

Now time from O to Q = 3 seconds where Q is the highest point of trajectory.

$$\therefore \frac{u \sin \alpha}{g} = 3 \Rightarrow u \sin \alpha = 3g \quad \dots (2)$$

$$\therefore \text{from (1), } u \cos \alpha = \sqrt{3} (3g - 2g) \Rightarrow u \cos \alpha = \sqrt{3}g \quad \dots (3)$$

Squaring and adding (2) and (3), we get,

$$u^2 = 9g^2 + 3g^2 = 12g^2 \Rightarrow u = 2\sqrt{3} \text{ gm/sec.}$$

Dividing (2) by (3), we get,  $\tan \alpha = \sqrt{3} \Rightarrow \alpha = 60^\circ$ .

**Example 4 :** Two particles are projected from the same point in the same vertical plane with equal velocities. If  $t, t'$  be the times taken to reach the other common point of their path and  $T, T'$  the times to the highest points, show that  $t T + t' T'$  is independent of the directions of projection.

**Sol.** Let  $u$  be the velocity of projection and  $\alpha, \beta$  the angles of projection of the two particles. Taking the horizontal and vertical lines through the point of projection as axes, the equations of the paths of the particles are

$$y = x \tan \alpha - \frac{gx^2}{2u^2 \cos^2 \alpha} \quad \dots (i)$$



$$\text{and } y = x \tan \beta - \frac{gx^2}{2u^2 \cos^2 \beta} \quad \dots (2)$$

Let (a, b) be the other common point of their paths

$\therefore$  point (a, b) lies on (1) as well as on (2).

$$\therefore b = a \tan \alpha - \frac{ga^2}{2u^2 \cos^2 \alpha} \quad \dots (3)$$

$$\text{and } b = a \tan \beta - \frac{ga^2}{2u^2 \cos^2 \beta} \quad \dots (4)$$

Subtracting (4) from (3), we get,

$$\begin{aligned} 0 &= a (\tan \alpha - \tan \beta) + \frac{ga^2}{2u^2} \left( \frac{1}{\cos^2 \beta} - \frac{1}{\cos^2 \alpha} \right) \\ \Rightarrow 0 &= a (\tan \alpha - \tan \beta) + \frac{ga^2}{2u^2} (\sec^2 \beta - \sec^2 \alpha) \\ \Rightarrow 0 &= a (\tan \alpha - \tan \beta) + \frac{ga^2}{2u^2} (\tan^2 \beta - \tan^2 \alpha) \\ \Rightarrow \alpha (\tan \alpha - \tan \beta) &= \frac{ga^2}{2u^2} (\tan \alpha - \tan \beta) (\tan \alpha + \tan \beta) \\ \Rightarrow \tan \alpha + \tan \beta &= \frac{2u^2}{ga} \quad \dots (5) \end{aligned}$$

We know that time to reach the highest point =  $\frac{1}{2} \times$  time of flight =  $\frac{u \sin \alpha}{g}$

$$\therefore T = \frac{u \sin \alpha}{g}, T' = \frac{u \sin \beta}{g} \quad \dots (6)$$

Also  $a = u \cos \alpha$  .  $t = u \cos \beta$  .  $t'$

$$\therefore t = \frac{a}{u \cos \alpha}, t' = \frac{a}{u \cos \beta} \quad \dots (7)$$

$$\therefore tT + t'T' = \frac{a}{u \cos \alpha} \cdot \frac{u \sin \alpha}{g} + \frac{a}{u \cos \beta} \cdot \frac{u \sin \beta}{g} \quad [ \because \text{of (6), (7)} ]$$

$$= \frac{a}{g} (\tan \alpha + \tan \beta) = \frac{a}{g} \cdot \frac{2u^2}{ga} \quad [\because \text{of (5)}]$$

$$= \frac{2u^2}{g^2}, \text{ which is independent of the directions } \alpha \text{ and } \beta.$$

**Example 5 :** A particle is projected with velocity  $u$  from a point on an inclined plane. If  $v_1$  be its velocity on striking the plane when the range up the plane is maximum and  $v_2$  the velocity on striking the plane when the range down the plane is maximum. Prove that  $u^2 = v_1 v_2$ .

**Sol.** Let  $\alpha$  be the inclination of the plane to the horizontal.

Let  $R$  be the maximum range up the plane.

$$\therefore R = \frac{u^2}{g(1 + \sin \alpha)} \quad \dots (1)$$

$$\text{Now } v_1^2 = u^2 - 2g \cdot R \sin \alpha \quad [\because v^2 = u^2 - 2gy]$$

$$u^2 - 2g \sin \alpha \cdot \frac{u^2}{g(1 + \sin \alpha)} \quad [\because \text{of (1)}]$$

$$= u^2 - \frac{2u^2 \sin \alpha}{1 + \sin \alpha} = \frac{u^2 + u^2 \sin \alpha - 2u^2 \sin \alpha}{1 + \sin \alpha}$$

$$\therefore v_1^2 = \frac{u^2(1 - \sin \alpha)}{1 + \sin \alpha} \quad \dots (2)$$

Changing  $\alpha$  to  $-\alpha$ , we have

$$v_2^2 = \frac{u^2(1 + \sin \alpha)}{1 - \sin \alpha} \quad \dots (3)$$

$$[\because \sin(-\alpha) = -\sin \alpha]$$

Multiplying (1) and (2), we get,

$$v_1^2 v_2^2 = u^4 \Rightarrow u^2 = v_1 v_2$$

### 2.4.6 Summary

In this lesson, we have studied the motion of a particle in a plane. We mainly focused on projectile motion and its associated terms. Further, we discussed about the motion of projectile on an inclined plane. The concepts are made easily understandable with the help of some solved examples.

### 2.4.7 Key Concepts

Projectile motion, Trajectory, Velocity of projection, Angle of projection, Range, Time of flight, Height of the directrix, Maximum horizontal range, Maximum height

### 2.4.8 Long Questions

1. A particle moves in a plane in such a way that its position  $(x, y)$  at any time  $t$  is given by  $x = 3t^2$ ,  $y = t^3 + 1$ . Find the equation of the path of the particle. Also find its velocity and acceleration at any time.
2. A stone is thrown from the top of a tower 9.8m high at an angle of elevation  $30^\circ$  with a velocity  $\frac{g}{\sqrt{3}}$  m/sec. Find its velocity and direction of motion on striking the horizontal plane through the foot of the tower.
3. A ball is thrown from a point P so to pass through another point Q whose horizontal and upward vertical distances from P are 3 metres and 4 metres respectively. Find the least possible velocity of projection, the velocity of ball and the time when it reaches Q.
4. If  $t_1$  and  $t_2$  are two times of flight with which given range R on a horizontal plane can be reached by a particle with velocity u, prove that  $t_1$  and  $t_2$  satisfy the equation  $g^2t^2 - 4u^2t^4 + 4R^2 = 0$ .

$$\text{Prove also that } t_1^2 + t_2^2 = \frac{4u^2}{g^2}.$$

5. A particle is projected with velocity u from a point on a plane inclined at an angle  $\alpha$  to the horizontal. If r and r' be the maximum ranges up and down the inclined plane, then prove that  $\frac{1}{r} + \frac{1}{r'}$  is independent of the inclination of the plane.

**2.4.9 Short Questions**

1. A particle is projected with a velocity  $u$  so that its range on a horizontal plane is twice the greatest height attained. Show that the range is  $\frac{4u^2}{5g}$ .
2. A particle is projected from a point  $O$  with given horizontal and vertical velocities  $u$  and  $v$  respectively. Show that the range on the horizontal plane through  $O$  is  $\frac{2uv}{g}$ .
3. Define time of flight.

**2.4.10 Suggested Readings**

1. S.L. Loney : The Elements of Statics and Dynamics, 5th Edition, Cambridge University Press, 1947.

## Mandatory Student Feedback Form

<https://forms.gle/KS5CLhvpwrpgjwN98>

Note: Students, kindly click this google form link, and fill this feedback form once.